

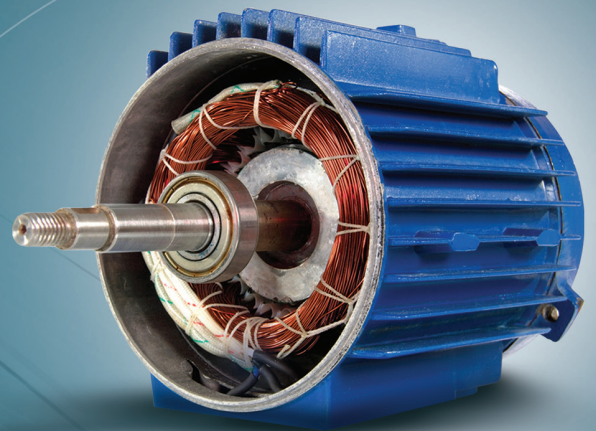

## Motor Control and Drive Design Solutions





## Microchip's Motor Control and Drive Solutions

Electric motors are estimated to consume around 45% of all electricity in the world today according to International Energy Agency (IEA). Electric motors are everywhere—in your washer, dryer, refrigerator, car, fan, pumps, air conditioner, etc. They make our lives easier, so it is important that they run as efficiently as possible.

Microchip provides products and solutions (hardware and software) to address the many different motor types, including brushed DC, stepper, brushless DC, permanent magnet synchronous, AC induction and switched reluctance motors. You can shorten your development cycle by using our free motor control software with application notes and tuning guides. Our scalable motor control development tools promote rapid prototyping for low-voltage and high-voltage systems including dual motor control options.

Microchip's PIC® Microcontrollers (MCUs), dsPIC® Digital Signal Controllers (DSCs) and SAM Cortex® series devices contain innovative motor control PWM peripherals including complimentary waveforms and dedicated time base. For applications that require variable speed with constant torque and field-oriented control for greater efficiency, the high-performance PIC32MK and dsPIC DSC core devices includes DSP instructions for more precise control.

Our single-chip motor control and motor drive solutions enable simpler designs and decrease board space, and are often used as companion chips with PIC MCUs, dsPIC DSCs and ARM® based MCUs.

## Benefits

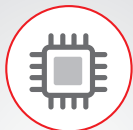

### Silicon Solutions

- Cost competitive
- Superior architecture
- Large compatible family



### Algorithms

- ACIM/BLDC/PMSM
- Brush DC/stepper
- Sensor/sensorless control
- Field-oriented control
- Power factor correction



### Reference Designs and GUI Tools

- Application note library with code
- Low-cost development tools
- Software GUIs for motor tuning
- Real-time motor parameter updates



### Technical Support

- Web design center
- Webinars
- Regional training center classes
- Motor control experts

## Need Design Assistance?

Microchip's Worldwide Design Partner network provides a channel between our authorized Design Partners and customers in need of technical expertise and cost-effective solutions in a timely manner. Visit [www.microchip.com/partners](http://www.microchip.com/partners) for a directory of third-party consultants and designers that can help with your motor control application.



# Brushed DC Motors

## Brushed DC Motor Control

Brushed DC (BDC) motors get their name from the "brushes" used for commutation. Brushed DC motors are easy to control because speed and torque are proportional to the applied voltage/current. The rotor is heavy due to windings on the armature; more inertia makes it more difficult to start/stop. Heat is generated in windings on the rotor and is difficult to remove.

### Key Characteristics of Brushed DC Motors

- Good controllability: on/off, proportional
- Linear torque/current curve
- Speed proportionate to voltage applied
- Maintenance required
- Low overloading capability
- Low heat dissipation

### Typical Applications

- Toys
- Mobile phones
- Window wipers
- Door locks
- Window lifts
- Antenna retractors
- Seat adjust
- Anti-lock braking systems
- Cordless hand drills
- Electric lawn mowers

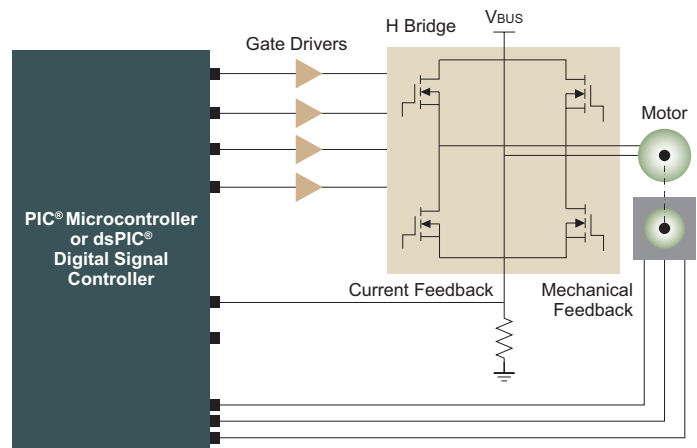

## Brushed DC Motor Application Notes

Algorithm	App Note
PIC18CXX/PIC16CXXX DC Servomotor Applications	AN696
Servo Control of a Brushed DC Motor	AN532
Low-Cost Bi-directional Brushed DC Motor Control Using the PIC16F684	AN893
Brushed DC Motor Fundamentals	AN905

## Brushed DC Motor Development Tools

### MTS2916A Dual Full-Bridge Stepper Motor Driver Evaluation Board (ADM00308)

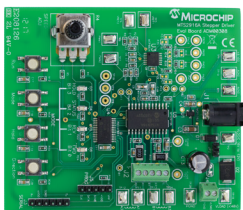

The MTS2916A Dual Full-Bridge Stepper Motor Driver Evaluation Board demonstrates the capabilities of the MTS2916A to control both windings of a bipolar stepper motor. The board also demonstrates the capabilities of controlling two brushed DC motors.

## Stepper Motor Control

Do you need exact position control with great holding torque? If so, then a stepper motor is the best solution. While nearly every MCU or DSC from Microchip can drive a stepper motor, some are better suited for this than others. Microchip offers a complete line of dual full-bridge drivers designed to drive bipolar stepper motors. These can be easily interfaced to any microcontroller. Also, Microchip's 8-bit PIC MCUs are an excellent solution for traditional stepper motor control. For advanced closed-loop stepper motor control, Microchip's dsPIC DSCs offer DSP performance and advanced motor control peripherals to enable sub micro-stepping, high-speed rotation and full torque output.

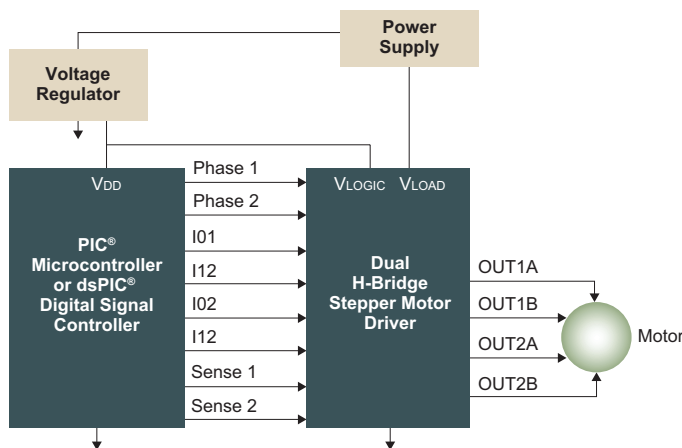

### Typical Applications

- Idle speed adjust
- Exhaust gas recirculation
- Duct airflow vanes
- Mirror control
- Telescopes
- Antennas
- Toys

## Stepper Motor Development Tools

### dsPICDEM™ Motor Control Stepper Motor (MCSM) Development Board/Kit (DM330022/ DV330021)

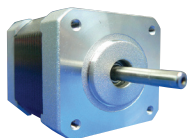

This board is targeted to control both unipolar and bipolar stepper motors in open- or closed-loop (current control) mode. The hardware is designed so that no changes are necessary for 8-, 6- or 4-wire stepper motors (bipolar or unipolar). Software to run in open- or closed-loop with full or variable micro-stepping is

provided as well as a GUI for controlling step commands, motor parameter input and operation modes. This flexible and cost-effective board can be configured in different ways for use with dsPIC33F motor control DSCs.

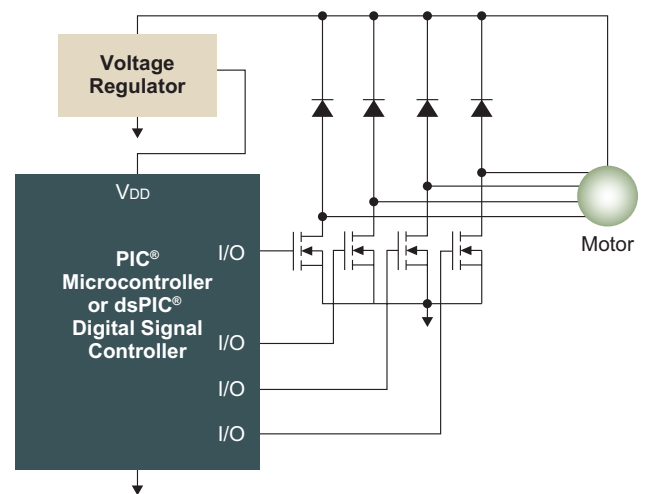

## Stepper Motor Application Notes

Algorithm	PIC16 Family	PIC18 Family	dsPIC® DSC Family
Full- and Half-Stepping	AN906 AN907	–	AN1307
Micro-Stepping	–	AN822	AN1307

### MTS2916A Stepper Motor Driver Evaluation Board (ADM00308)

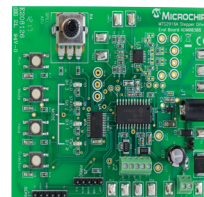

This evaluation board includes push-button switches and a variable-speed input potentiometer to demonstrate the MTS2916A controlling a stepper motor in full-step, half-step, modified half-step and micro-stepping modes.

# Brushless DC Motor Control

## BLDC Motor Control

Looking for a high reliability, high efficiency and high power-to-size ratio motor? The obvious solution is a Brushless DC (BLDC) motor. It shares many of the same torque and speed characteristics with the brushed DC motor, but does not include the brushes. Technically it is a Permanent Magnet Synchronous Motor (PMSM), but its name comes from the simple method of commutation. In some cases the stator windings are constructed to match the non-sinusoidal commutation.

The simpler commutation method allows the use of a wide range of Microchip products, from 8-bit PIC16 MCUs, to MTD650X dedicated BLDC driver chips, to dsPIC DSCs. The device best suited to your application depends on what you are trying to achieve: performance, cost, efficiency, time to market, etc. Our wide range of application notes and development tools will allow you to get started with your application quickly.

### Typical Applications

- Anti-lock braking systems
- Disk drive servos
- Throttle control
- Fuel pumps
- Oil pumps

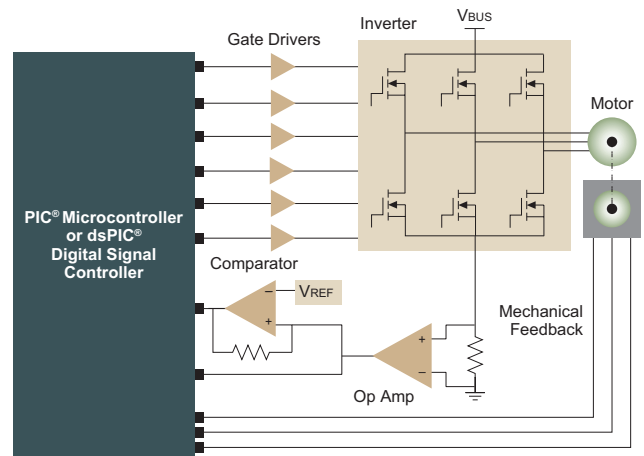

## BLDC Fan Motor Control

Need a highly integrated fan controller with a customizable speed/temperature profile? Take a look at Microchip's PIC12HV and PIC16HV devices. These devices have a built-in 5V regulator and on-chip comparator to save system cost. The rotor position is determined by a Hall-effect sensor connected to the on-chip comparator. The Enhanced Capture Compare PWM (ECCP) Module uses this feedback information to drive the motor by steering the PWM signal to the appropriate motor phase. Temperature sensor inputs can be used to create a unique fan speed profile, and the application can provide digital status information to a host device.

If space or time to market is a concern for your next project, Microchip's 3-phase full-wave sensorless drivers for BLDC motors are the answer. These devices feature 180° sinusoidal drive, high torque output and silent drive. With the adaptive features, parameters and wide range of power supplies, they work standalone or with Microchip's broad range of microcontrollers.

### Typical Applications

- Seat cooling fans
- Server cooling fans

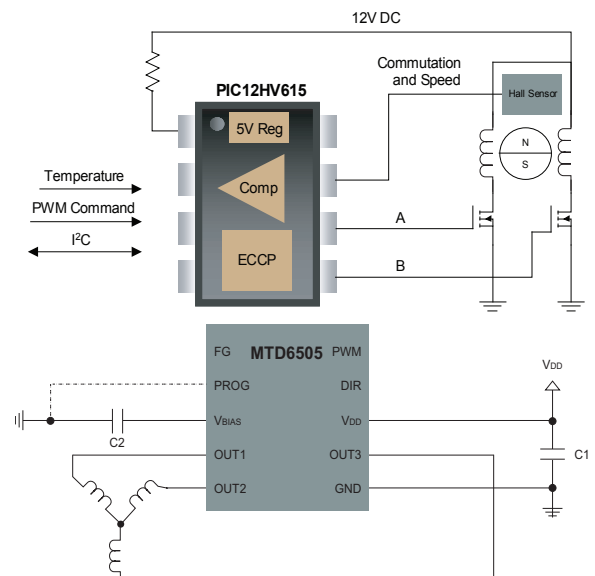

## BLDC Application Notes and Tuning Guides

Algorithm	PIC16 Family	PIC18 Family	dsPIC® DSC Family	App Note	32-Bit Family	42711A
Sensored	AN885, AN1779, AN2049	AN899	AN957	–		
Sensored Sinusoidal	–	–	AN1017	–		
Sensorless BEMF	AN1175, AN1305, AN857	AN970	AN901, AN992	–		
Sensorless Filtered BEMF with Majority Detect	–	–	–	AN1160		
Tuning Guide: Sensorless BLDC Control with Back-EMF Filtering Using a Majority Function	–	–	–	AN1160		

## BLDC Development Tools

### Motor Control Starter Kit (MCSK) (DM330015)

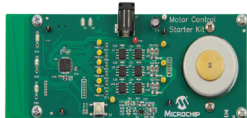

This starter kit with mTouch® sensing is a complete, integrated development platform based on the dsPIC33FJ16MC102. It includes a

USB interfaced debugger/programmer, a complete drive circuit, an on-board BLDC motor, a user-configurable switch and an mTouch sensing slider with LED indicators for speed control.

### dsPICDEM MCHV-2/3 Development System (DM330023-2/3)



This high-voltage system is intended to aid you in the rapid evaluation and development of a wide variety of motor control applications using a dsPIC DSC. This development system is targeted to control BLDC motors, PMSMs and

ACIMs in sensor or sensorless operation. The rated continuous output current from the inverter is 6.5A (RMS). This allows up to approximately 2 kVA output when running from a 208V to 230V single-phase input voltage. The MCHV-3 adds Power Factor Correction (PFC) with current feedback circuitry and zero-crossing detection.

### dsPICDEM MCLV-2 Development Board (DM330021-2)

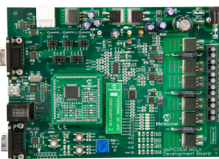

This low-voltage development board provides a cost-effective method of evaluating and developing sensored or sensorless BLDC motor and PMSM control applications. The

board supports Microchip's 100-pin PIM with dsPIC33E or dsPIC33F DSCs. It also supports the use of the internal, on-chip op amps found on certain dsPIC DSCs or the external op amps found on the dsPICDEM MCLV-2 Development Board. A dsPIC33EP256MC506 Internal Op Amp PIM (MA330031) is included, and the board is capable of controlling motors rated up to 48V and 15A, with multiple communication channels such as USB, CAN, LIN and RS-232.

### Low-Voltage Motor Control Development Bundle (Single Board and Drive Board) (DV330100)

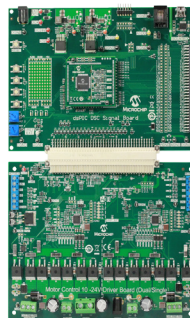

This bundle provides a cost-effective method of evaluating and developing dual/single motor control to drive BLDC motors or PMSMs concurrently, or one of each type of motor. The dsPIC DSC Signal Board supports both 3.3V and 5V devices for various applications and frequently used human interface includes some features and communication interfaces. The Motor Control 10–24V Driver Board (Dual/Single) supports currents up to 10A.

### SAM BLDC 24V Motor Control Kit (ATSAMD21BLDC24V-STK)

This low-voltage development board provides a method for evaluating BLDC and PMSM motor control performance of the SAM C and SAM D series Cortex M0+ devices. This board supports specific ARM Cortex plug-in-modules and is not compatible with dsPIC or PIC32 plug-in modules. This kit ships with a SAMD21 Motor control card, is also compatible with the ATSAMC21MOTOR plug-in-module offering increased performance, 5V power supplies, and CAN-FD. Software for this kit is available in Studio Framework and START.

## BLDC Fan Control Development Tools

### MTD6505 3-Phase BLDC Sensorless Fan Controller Demonstration Board (ADM00345)

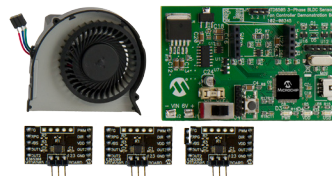

This board allows for the control and monitoring of the MTD6505 device using PC software connected to the board via a USB connection.

# Permanent Magnet Synchronous Motors

## PMSM Control

Permanent Magnet Synchronous Motors (PMSM) are brushless and have very high reliability and high efficiency. Due to their permanent magnet rotor, they also have higher torque with smaller frame size and no rotor current, all of which are advantages over AC induction motors. With a high power-to-size ratio, PMSMs can help you make your design smaller without the loss of torque. PMSMs need to be commutated like BLDC motors, but due to the construction of the windings, the waveforms need to be sinusoidal for good performance. This requires more complicated control algorithms and, therefore, a higher performing controller like Microchip's dsPIC DSCs and 32-Bit PIC32MK or Cortex M based solutions. Microchip offers development tools and applications notes to help you develop advanced PMSM control solutions like sensorless Field-Oriented Control (FOC).

## Typical Applications

- Air conditioner and refrigerator compressors
- Direct-drive washing machines
- Automotive electrical power steering
- Machining tools
- Traction control
- Industrial sewing machines

## PMSM Development Tools

### dsPICDEM MCLV-2 Development Board (DM330021-2)

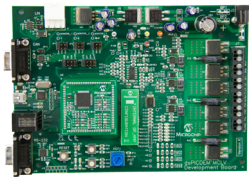

This low-voltage development board provides a cost-effective method of evaluating and developing sensed or sensorless Brushless DC (BLDC) motor and Permanent Magnet Synchronous

Motor (PMSM) control applications. The board supports Microchip's 100-pin PIM with dsPIC33E, dsPIC33F DSCs and 32-Bit PIC32MKMC devices. It also supports the use of the internal, on-chip op amps found on certain dsPIC DSCs and PIC32MKMC or the external op amps found on the MCLV-2 board. A dsPIC33EP256MC506 Internal Op Amp PIM (MA330031) is included. For PIC32MK support, the PIC32MK1024 PIM (MA320024) is available. The board is capable of controlling motors rated up to 48V and 15A, with multiple communication channels such as USB, CAN, LIN and RS-232.

### 24V 3-Phase Brushless DC Motor (AC300020)



The 24V 3-phase BLDC motor with Hall effect sensors can be used with the dsPICDEM MCLV-2 Development Board (DM330021-2).

### 24V 3-Phase Brushless DC Motor with Encoder (AC300022)



This Brushless DC (BLDC) motor has a 250-line encoder, and can be used with the dsPICDEM MCLV-2 Development Board (DM330021-2).

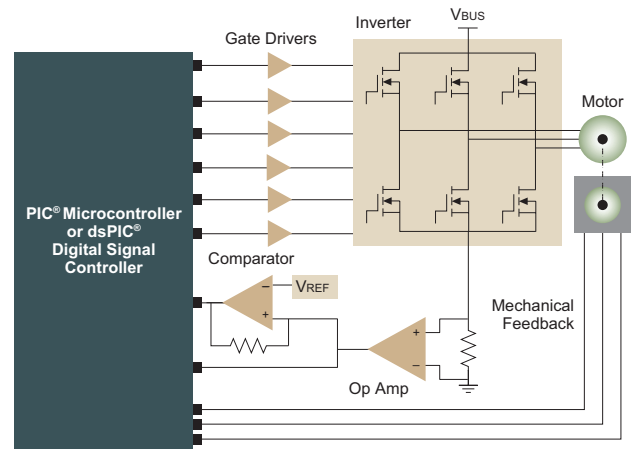

### dsPICDEM MCHV-2/3 Development System (DM330023-2/3)



This high-voltage system is intended to aid you in the rapid evaluation and development of a wide variety of motor control applications using a dsPIC DSC. This development system is targeted to control BLDC motors, PMSMs and ACIMs in

sensor or sensorless operation. The rated continuous output current from the inverter is 6.5A (RMS). This allows up to approximately 2 kVA output when running from a 208V to 230V single-phase input voltage. The MCHV-3 adds PFC with current feedback circuitry and zero-crossing detection.

### Low-Voltage Motor Control Development Bundle (Single Board and Drive Board) (DV330100)

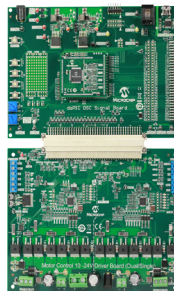

This bundle provides a cost-effective method of evaluating and developing dual/single motor control to drive BLDC motors or PMSMs concurrently, or one of each type of motor. The dsPIC DSC Signal Board supports both 3.3V and 5V devices for various applications and frequently used human interface includes some features and communication inter-

faces. The Motor Control 10–24V Driver Board (Dual/Single) supports currents up to 10A.

## PMSM Libraries

### Motor Control Library for dsPIC33F/dsPIC33E

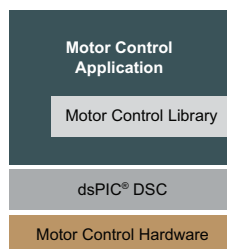

The Motor Control Library contains function blocks that are optimized for the dsPIC33F and dsPIC33E DSC families. All functions in this Motor Control Library have input(s) and output(s), but do not access any of the DSC peripherals. The library functions are designed to be used within an

application framework for realizing an efficient and flexible way of implementing a motor control application.

### motorBench™ Development Suite

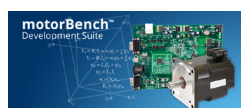

This tool identifies the electrical and mechanical parameters of a motor and then automatically tunes the current and speed control loops. It

then generates complete dsPIC33 motor control code into an MPLAB® X IDE project. Version 1.x works with the low-voltage development board (MCLV-2: DM330021-2) and one permanent magnet synchronous motor (AC300022).

### Microchip Motor Control Library Blockset

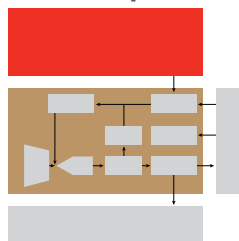

The Microchip Motor Control Library Blockset contains a number of basic Simulink® blocks that can be used to jump start model-based design of motor control applications using Microchip's dsPIC33F and dsPIC33E DSC families. These blocks include reference frame transforms, a

proportional-integral controller and trigonometric functions, all of which can be used with Embedded Coder® to generate efficient code on the dsPIC DSC that utilizes the Microchip Motor Control Library.

## PMSM Application Notes and Tuning Guides

Algorithm	App Note
Sensored Sinusoidal	AN1017
Sensorless Dual-Shunt FOC with SMO Estimator and Field Weakening	AN1078
Sensorless Dual-Shunt FOC with SMO and PFC	AN1208
Sensorless Dual-Shunt FOC with PLL Estimator and Field Weakening	AN1292
Sensorless Single-Shunt FOC with SMO Estimator and Field Weakening	AN1299
Sensorless Dual-Shunt FOC with SMO Estimator PMSM	AN1078
Sensorless Dual-Shunt FOC with PLL Estimator PMSM	AN1292
Tuning Guide: Sensorless Single-Shunt FOC with SMO Estimator PMSM	AN1299



## AC Induction Motor Control

The AC Induction Motor (ACIM) is the workhorse of the motor world. It is the most common motor type, used in everything from consumer products to heavy industry. Its simple design with no brushes makes it highly reliable and also allows it to be manufactured at a low cost. But, it is less efficient than other motors like PMSM, which is partially related to the heat generation in the rotor windings.

The open-loop voltage/frequency (V/f) drive technique is traditionally used to control ACIMs and it can be implemented on an 8-bit PIC MCU. This drive technique is not very efficient, so for applications that need higher efficiency, an advanced control solution like Field-Oriented Control can be applied. This requires a high-performance controller, like a dsPIC DSC.

### Typical Applications

- Air conditioner and refrigerator compressors
- Home appliances
- Pumps
- Blowers
- Automation/industrial applications
- Power tools

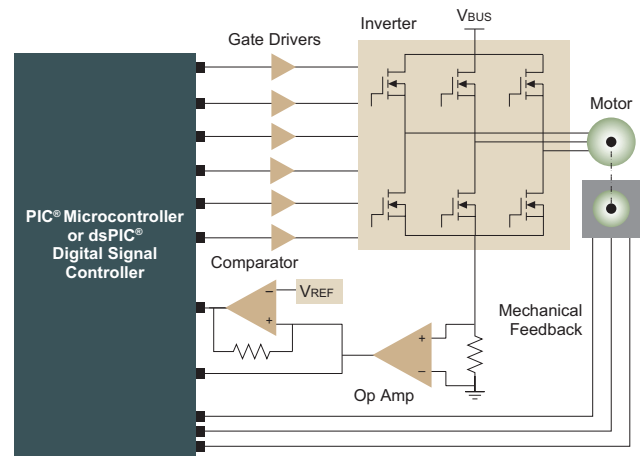

## AC Induction Motor Application Notes

Algorithm	PIC16 Family	PIC18 Family	dsPIC® DSC Family
Open-Loop V/f	AN887, AN889, AN955, AN967, AN1660	AN900, AN843	AN984
Closed-Loop Vector Control	–	–	AN908
Sensorless Dual-Shunt FOC with PLL Estimator	–	–	AN1162
Sensorless Dual-Shunt FOC with PLL Estimator and Field Weakening	–	–	AN1206

## AC Induction Motor Development Tools

### dsPICDEM MCHV-2/3 Development System (DM330023-2/3)



This high-voltage system is intended to aid the user in the rapid evaluation and development of a wide variety of motor control applications using a dsPIC DSC. This development system is targeted to control BLDC motors, PMSM and AC Induction

Motors (ACIM) in sensor or sensorless operation. The rated continuous output current from the inverter is 6.5A (RMS). This allows up to approximately 2 kVA output when running from a 208V to 230V single-phase input voltage. The MCHV-3 adds PFC with current feedback circuitry and zero-crossing detection.

### AC Induction Motor (AC300023)

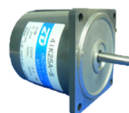

This compact 3-phase AC Induction Motor has been certified for use with dsPIC33 ACIM motor control application notes in conjunction with the dsPICDEM MCHV-2 Development System (DM330023-2).

**Recommended Products for Brushed DC Motor Control**

Device	Pins	Flash (KB)	SRAM (Bytes)	EE (Bytes)	HEF	ADC	Comparator	CCP/ECCP	PWM (10-/16-bit)	CWG/COG	DAC (5-/8-/9-/10-bit)	Timer (8-/16-bit)	CLC	SMT	Angular Timer	NCO	Math Accelerator	PPS	Op Amp	EUSART/AUSART	MSSP	SPI/I <sup>2</sup> C
PIC10F322	6	0.875	64	-	-	3 ch, 8-bit	-	-	2/0	1	-	2/1	1	-	-	1	-	-	-	-	-	-
PIC12F/HV615	8	1.75	64	-	-	4 ch, 10-bit	1	0/1	-	-	-	2/1	-	-	-	-	-	-	-	-	-	-
PIC12F1572	8	3.5	256	-	✓	4 ch, 10-bit	1	-	0/3	1/0	1/0/0/0	2/1	-	-	-	-	-	-	-	1/0	-	-
PIC16F15313	8	3.5	256	-	✓	5 ch, 10-bit	2	1/0	4/0	1/0	1/0/0/0	1/2	4	-	-	1	-	✓	-	1/0	1	-
PIC16F15323	14	3.5	256	-	✓	11 ch, 10-bit	2	2/0	4/0	1/0	1/0/0/0	1/2	4	-	-	1	-	✓	-	1/0	1	-
PIC16F1509	20	14	512	-	✓	12 ch, 10-bit	2	-	4/0	1/0	-	2/1	4	-	-	1	-	-	-	1/0	1	-
PIC16F1618	20	7	512	-	✓	12 ch, 10-bit	-	2/0	2/0	1/0	0/1/0/0	3/1	4	2	1	-	1	-	-	1/0	1	-
PIC16F1936	28	14	512	256	✓	11 ch, 10-bit	2	2/3	-	-	-	4/1	4	-	-	-	-	-	-	1/0	1	-
PIC16F15355	28	14	1K	-	✓	24 ch, 10-bit	2	2/0	4/0	1/0	1/0/0/0	1/2	4	-	-	1	-	✓	-	2/0	-	1
PIC16F18856	28	28	2K	256	✓	24 ch, 10-bit	2	5/0	2/0	1/0	1/0/0/0	1/2	4	2	-	1	-	✓	-	1/0	-	1
PIC16F1939	40/ 44	28	1K	256	✓	14 ch, 10-bit	2	2/3	-	-	-	4/1	4	-	-	-	-	-	-	1/0	1	-

Device	Motor Type	Input Voltage Range (V)	Output Current (mA)	Control Scheme	Temp. Operating Range (°C)	Features	Packages
MTS62C19A	One Bipolar Stepper Motor or Two DC Motors	10.0 to 40.0	750	Direct PWM Input, Current Limit Control, Micro-stepping	-40 to +105	Over-Temperature Protection, Under-Voltage Protection, Dual Full-Bridge Motor Driver, Micro-stepping, Pin-compatible with ST L6219	24-pin SOIC
MTS2916A	One Bipolar Stepper Motor or Two DC Motors	10.0 to 40.0	750	Direct PWM Input, Current Limit Control, Micro-stepping	-40 to +105	Over-Temperature Protection, Under-Voltage Protection, Dual Full-Bridge Motor Driver, Micro-stepping, Pin-compatible with Allegro UDX2916 and A4970	24-pin SOIC

Device	Configuration	Temp. Operating Range (°C)	Peak Output Current (A)	Output Resistance (R <sub>H</sub> /R <sub>L</sub> ) (Max. Ω @ 25 °C)	Maximum Supply Voltage (V)	Input/Output Delay (t <sub>D1</sub> , t <sub>D2</sub> ) (ns)	Packages
MCP14700	Dual, Non-inverting	-40 to +125	2	2.5/2.5	5 (V <sub>DD</sub> ), 36 (Boot Pin)	25/25	8-pin SOIC, 8-pin 3 × 3 DFN

## Recommended Products for Stepper Motor Control

Device	Pins	Flash (KB)	SRAM (Bytes)	EE (Bytes)	HEF	ADC (10-bit)	Comparator	CCP/ECCP	PWM (10-/16-bit)	CWG/COG	DAC (5-/8-/9-/10-bit)	Timer (8-/16-bit)	CLC	SMT	Angular Timer	NCO	Math Accelerator	PPS	Op Amp	EUSART/AUSART	MSSP	SPI/I <sup>2</sup> C
PIC16F15323	14	3.5	256	-	✓	11 ch	2	2/0	4/0	1/0	1/0/0/0	1/2	4	-	-	1	-	✓	-	1/0	1	-
PIC16F18324	14	7	512	256	✓	11 ch	2	4/0	2/0	1/0	1/0/0/0	4/3	4	2	-	1	-	✓	-	1/0	1	-
PIC16F1509	20	14	512	-	✓	12 ch	2	-	4/0	1/0	-	2/1	4	-	-	1	-	-	-	1/0	1	-
PIC16F1618	20	7	512	-	✓	12 ch	-	2/0	2/0	1/0	0/1/0/0	3/1	4	2	1	-	1	-	-	1/0	1	-
PIC16F1936	28	14	512	256	✓	11 ch	2	2/3	-	-	-	4/1	4	-	-	-	-	-	-	1/0	1	-
PIC16F15355	28	14	1K	-	✓	24 ch	2	2/0	4/0	1/0	1/0/0/0	1/2	4	-	-	1	-	✓	-	2/0	-	1
PIC16F18856	28	28	2K	256	✓	24 ch	2	5/0	2/0	1/0	1/0/0/0	4/3	4	2	-	1	-	✓	-	1/0	-	1
PIC16F1939	40/ 44	28	1K	256	✓	14 ch	2	2/3	-	-	-	4/1	4	-	-	-	-	-	-	1/0	1	-

Device	Motor Type	Input Voltage Range (V)	Output Current (mA)	Control Scheme	Temp. Operating Range (°C)	Features	Packages
MTS62C19A	One Bipolar Stepper Motor or Two DC Motors	10.0 to 40.0	750	Direct PWM Input, Current Limit Control, Micro-stepping	-40 to +105	Over-Temperature Protection, Under-Voltage Protection, Dual Full-Bridge Motor Driver, Micro-stepping, Pin-compatible with ST L6219	24-pin SOIC
MTS2916A	One Bipolar Stepper Motor or Two DC Motors	10.0 to 40.0	750	Direct PWM Input, Current Limit Control, Micro-stepping	-40 to +105	Over-Temperature Protection, Under-Voltage Protection, Dual Full-Bridge Motor Driver, Micro-stepping, Pin-compatible with Allegro UDX2916 and A4970	24-pin SOIC

Device	Max. Input Voltage (V)	Output Voltage (V)	Output Current (mA)	Junction Temp. Range (°C)	Typical Active Current (µA)	Typical Dropout Voltage @ Max. I <sub>out</sub> (mV)	Typical Output Voltage Accuracy (%)	Features	Packages
MIC5205	2.5 to 16	2.5, 2.7, 2.8, 2.85, 2.9, 3.0, 3.1, 3.2, 3.3, 3.6, 3.8, 4.0, 5.0, Adj.	150	-40 to +125	80	165	±1	Ultra-low noise output	5-pin SOT-23
MCP1754	16	1.8, 2.5, 2.7, 2.8, 2.85, 3.0, 3.3, 3.6, 4.0, 5.0	150	-40 to +125	50	300	±2	70 dB PSRR	5-pin SOT-23, 3-pin, SOT-89, 3-pin SOT-223, 8-pin 2 × 3 TDFN

## Recommended Products for Stepper Motor Control

Device	Pins	Flash (KB)	RAM (KB)	DMA # Ch	Timer 16-bit	Input Capture	Output Compare/Standard PWM	Motor Control PWM Ch	QEI	ADC 10-/12-bit <sup>(1)</sup> 1.1/0.5 Msps	Analog Comparators	CodeGuard™ Security Segments	UART	SPI	I <sup>2</sup> C	PMP	RTCC	CAN	Package	Temperature Range <sup>(3)</sup>
dsPIC33FJ12MC202	28	12	1	–	3	4	2	6+2 ch	1	1 ADC, 6 ch	–	2	1	1	1	–	–	0	SO, SP, ML	I,E
dsPIC33FJ32MC202	28	32	2	–	3	4	2	6+2 ch	1	1 ADC, 6 ch	–	2	1	1	1	–	–	0	SO, SP, MM	I,E
dsPIC33FJ32MC302	28	32	4	8	5	4	4	6+2 ch	2	1 ADC, 6 ch	2	–	2	2	1	1	1	–	SO, SP, MM	I,E,H
dsPIC33FJ64MC202	28	64	8	8	5	4	4	6+2 ch	2	1 ADC, 6 ch	2	–	2	2	1	1	1	–	SO, SP, MM	I,E,H
dsPIC33FJ64MC802	28	64	16	8	5	4	4	6+2 ch	2	1 ADC, 9 ch	2	–	2	2	1	1	1	1	SO, SP, MM	I,E,H
dsPIC33EP128GM304	44	128	16	4	9	8	8	12 ch	2	2 ADC, 18 ch	5	1	4	3	2	–	–	–	ML, PT	I,E, H
dsPIC33EP128GM604	44	128	16	4	9	8	8	12 ch	2	2 ADC, 18 ch	5	1	4	3	2	–	–	2	ML, PT	I,E, H
dsPIC33EP128GM306	64	128	16	4	9	8	8	12 ch	2	2 ADC, 30 ch	5	1	4	3	2	1	–	–	ML, PT	I,E, H
dsPIC33EP128GM706	64	128	16	4	9	8	8	12 ch	2	2 ADC, 30 ch	5	1	4	3	2	1	–	2	ML, PT	I,E, H
dsPIC33EP128GM310	100	128	16	4	9	8	8	12 ch	2	2 ADC, 49 ch	5	1	4	3	2	1	–	–	PT, BG	I,E, H
dsPIC33EP128GM710	100	128	16	4	9	8	8	12 ch	2	2 ADC, 49 ch	5	1	4	3	2	1	–	2	PT, BG	I,E, H
dsPIC33EP256GM304	44	256	32	4	9	8	8	12 ch	2	2 ADC, 18 ch	5	1	4	3	2	–	–	–	ML, PT	I,E, H
dsPIC33EP256GM604	44	256	32	4	9	8	8	12 ch	2	2 ADC, 18 ch	5	1	4	3	2	–	–	2	ML, PT	I,E, H
dsPIC33EP256GM306	64	256	32	4	9	8	8	12 ch	2	2 ADC, 30 ch	5	1	4	3	2	1	–	–	ML, PT	I,E, H
dsPIC33EP256GM706	64	256	32	4	9	8	8	12 ch	2	2 ADC, 30 ch	5	1	4	3	2	1	–	2	ML, PT	I,E, H
dsPIC33EP256GM310	100	256	32	4	9	8	8	12 ch	2	2 ADC, 49 ch	5	1	4	3	2	1	–	–	PT, BG	I,E, H
dsPIC33EP256GM710	100	256	32	4	9	8	8	12 ch	2	2 ADC, 49 ch	5	1	4	3	2	1	–	2	PT, BG	I,E, H
dsPIC33EP512GM304	44	512	48	4	9	8	8	12 ch	2	2 ADC, 18 ch	5	1	4	3	2	–	–	–	ML, PT	I,E, H
dsPIC33EP512GM604	44	512	48	4	9	8	8	12 ch	2	2 ADC, 18 ch	5	1	4	3	2	–	–	2	ML, PT	I,E, H
dsPIC33EP512GM306	64	512	48	4	9	8	8	12 ch	2	2 ADC, 30 ch	5	1	4	3	2	1	–	–	ML, PT	I,E, H
dsPIC33EP512GM706	64	512	48	4	9	8	8	12 ch	2	2 ADC, 30 ch	5	1	4	3	2	1	–	2	ML, PT	I,E, H
dsPIC33EP512GM310	100	512	48	4	9	8	8	12 ch	2	2 ADC, 49 ch	5	1	4	3	2	1	–	–	PT, BG	I,E, H
dsPIC33EP512GM710	100	512	48	4	9	8	8	12 ch	2	2 ADC, 49 ch	5	1	4	3	2	1	–	2	PT, BG	I,E, H

Note 1: dsPIC33 devices feature one or two user-selectable 1.1 Msps 10-bit ADC (4 S & H) or 500 kbps 12-bit ADC (1 S & H).  
 2: A DAC is associated with each analog comparator to set a programmable voltage reference. One DAC output may be selected by software and driven on an external pin.  
 3: I = Industrial Temperature Range (–40°C to +85°C), E = Extended Temperature Range (–40°C to +125°C), H = High Temperature Range (–40°C to +140°C).

## Recommended Products for Brushless Fan Control

Device	Input Voltage Range (V)	Output Current (mA)	Control Scheme	Temp. Operating Range (°C)	Features	Packages
MCP8063	2.0 to 5.5	1600	Sensorless Sinusoidal	–40 to +125	180° Sinusoidal Drive, Direction Control, Programmable BEMF Coefficient Range, Current Limitation, Lock-up Recover, Over-Temperature Protection, Output Switching Frequency at 23 kHz	8-pin 4 × 4 DFN
MTD6505	2.0 to 5.5	750	Sensorless Sinusoidal	–40 to +125	180° Sinusoidal Drive, Direction Control, Programmable BEMF Coefficient Range, Current Limitation, Lock-up Recover, Over-Temperature Protection, Output Switching Frequency at 30 kHz	10-pin 3 × 3 UDFN
MTD6501C	2.0 to 14.0	800	Sensorless Sinusoidal	–30 to +95	180° Sinusoidal Drive, Current Limitation, Lock-up Recover, Over-Temperature Protection, Output Switching Frequency at 20 kHz	Thermally Enhanced 8-pin SOP
MTD6501D	2.0 to 14.0	500	Sensorless Sinusoidal	–30 to +95	180° Sinusoidal Drive, Current Limitation, Lock-up Recover, Over-Temperature Protection, Output Switching Frequency at 20 kHz	10-pin MSOP
MTD6501G	2.0 to 14.0	800	Sensorless Sinusoidal	–30 to +95	180° Sinusoidal Drive, Current Limitation, Lock-up Recover, Over-Temperature Protection, Output Switching Frequency at 23 kHz	Thermally Enhanced 8-pin SOP

## Recommended Products for Brushless Fan Control (Continued)

Device	Pins	Flash (KB)	SRAM (Bytes)	EE (Bytes)	Timer 8/16-bit	Comp.	CCP/ECCP	Motor Control PWM	ADC	UART	SPI/I <sup>2</sup> C
PIC16F616/ PIC16HV616 <sup>(1)</sup>	14	3.5	128	–	2/1	2	0/1	–	8 ch, 10-bit	–	–
PIC16F684	14	3.5	128	256	2/1	2	0/1	–	8 ch, 10-bit	–	–
PIC16F1509	20	14	512	–	2/1	2	–	4	12 ch, 10-bit	1	1
PIC16F1783	28	7	512	256	4/1	3	2	–	11 ch, 12-bit	1	1
PIC16F1823	14	3.5	128	256	2/1	2	0/1	–	8 ch, 10-bit	1	1
PIC16F1933	28	7	256	256	4/1	2	2/3	–	11 ch, 10-bit	1	1
PIC16F1936	28	14	512	256	4/1	2	2/3	–	11 ch, 10-bit	1	1
PIC16F1937	40/44	14	512	256	4/1	2	2/3	–	14 ch, 10-bit	1	1
PIC16F1939	40/44	28	1024	256	4/1	2	2/3	–	14 ch, 10-bit	1	1

Note 1: HV device has on-chip shunt regulator.

## Recommended Products for Brushless DC Motors

Device	Input Voltage Range (V)	Output Current (mA)	Control Scheme	Temp. Operating Range (°C)	Features	Integrated Op Amps	Packages
MCP8024	6.0 to 28	500	PWM	–40 to +150	Adjustable Output Buck Regulator, 5V and 12V LDOs, Over-Current Comparator, Under-Voltage/Over-Voltage Lockout, Current Limitation	3	40-pin QFN, 48-pin, TQFP
MCP8025	6.0 to 19	500	PWM	–40 to +150	LIN Transceiver, Adjustable Output Buck Regulator, 5V and 12V LDOs, Over-Current Comparator, Under-Voltage/Over-Voltage Lockout, Current Limitation	1	40-pin QFN, 48-pin TQFP
MCP8026	6.0 to 28	500	PWM	–40 to +150	Adjustable Output Buck Regulator, 5V and 12V LDOs, Over-Current Comparator, Under-Voltage/Over-Voltage Lockout, Current Limitation	3	40-pin QFN, 48-pin TQFP

Device	Pins	Flash (KB)	SRAM (Bytes)	EE (Bytes)	HEF	ADC (10-bit)	Comparator	CCP/ECCP	PWM (10-/16-bit)	CWG/COG	DAC (5-/8-/9-/10-bit)	Timer (8-/16-bit)	CLC	SMT	Angular Timer	NCO	Math Accelerator	PPS	Op Amp	EUSART/AUSART	MSSP	SPI/I <sup>2</sup> C
PIC16F15323	14	3.5	256	–	✓	11 ch	2	2/0	4/0	1/0	1/0/0/0	1/2	4	–	–	1	–	✓	–	1/0	1	–
PIC16F1509	20	14	512	–	✓	12 ch	2	–	4/0	1/0	–	2/1	4	–	–	1	–	–	–	1/0	1	–
PIC16F1619	20	14	1K	–	✓	12 ch	–	2/0	2/0	1/0	0/1/0/0	3/1	4	2	1	–	1	–	–	1/0	1	–
PIC16F1936	28	14	512	256	✓	11 ch	2	2/3	–	–	–	4/1	4	–	–	–	–	–	–	1/0	1	–
PIC16F15355	28	14	1K	–	✓	24 ch	2	2/0	4/0	1/0	1/0/0/0	1/2	4	–	–	1	–	✓	–	2/0	–	1
PIC16F18856	28	28	2K	256	✓	24 ch	2	5/0	2/0	1/0	1/0/0/0	1/2	4	2	–	1	–	✓	–	1/0	–	1
PIC16F1718	28	28	2K	–	✓	17 ch	–	2/0	2/0	1/0	1/1/0/0	4/1	4	–	–	1	–	–	2	1/0	1	–
PIC16F1939	40/ 44	28	1K	256	✓	14 ch	2	2/3	–	–	–	4/1	4	–	–	–	–	–	–	1/0	1	–
PIC16F15376	40	28	2K	–	✓	35 ch	2	2/0	4/0	1/0	1/0/0/0	1/2	4	–	–	1	–	✓	–	2/0	–	1

## Recommended Products for ACIMs

Device	Pins	Flash (KB)	SRAM (Bytes)	EE (Bytes)	HEF	ADC (10-bit)	Comparator	CCP/ECCP	PWM (10-/16-bit)	CWG/COG	DAC (5-/8-/9-/10-bit)	Timer (8-/16-bit)	CLC	SMT	Angular Timer	NCO	Math Accelerator	PPS	Op Amp	EUSART/AUSART	MSSP	SPI/I <sup>2</sup> C
PIC16F1509	20	14	512	-	✓	12 ch	2	-	4/0	1/0	-	2/1	4	-	-	1	-	-	-	2/0	1	-
PIC16F15323	14	3.5	256	-	✓	11 ch	2	2/0	4/0	1/0	1/0/0/0	1/2	4	-	-	1	-	✓	-	1/0	1	-
PIC16F15344	20	7	512	-	✓	11 ch	2	2/0	4/0	1/0	1/0/0/0	1/2	4	-	-	1	-	✓	-	1/0	1	-
PIC16F1619	20	14	1K	-	✓	12 ch	-	2/0	2/0	1/0	0/1/0/0	3/1	4	2	1	-	1	-	-	1/0	1	-
PIC16F1936	28	14	512	256	✓	11 ch	2	2/3	-	-	-	4/1	4	-	-	-	-	-	-	1/0	1	-
PIC16F15355	28	14	1K	-	✓	24 ch	2	2/0	4/0	1/0	1/0/0/0	1/2	4	-	-	1	-	✓	-	2/0	-	1
PIC16F18856	28	28	2K	256	✓	24 ch	2	5/0	2/0	1/0	1/0/0/0	1/2	4	2	-	1	-	✓	-	1/0	-	1

## Recommended Products for Brushless DC Motors, PMSMs and ACIMs

Device	Pins	Flash (KB)	RAM (KB)	DMA # Ch	Timer 16-bit	Input Capture	Output Compare/Standard PWM	Motor Control PWM Ch	QEI	ADC	Analog Comparators	Op Amps	CodeGuard™ Security Segments	UART	SPI	I <sup>2</sup> C	PMP	RTCC	CAN	USB 2.0	Package	Temperature Range <sup>(b)</sup>
dsPIC33EP32MC202	28	32	4	4	5	4	4	6	1	1 ADC, 6 ch	1 + 2 <sup>(2)</sup>	2	1	2	2	2	-	-	-	-	SP, SO, SS, MM	I,E, H
dsPIC33EP32MC502	28	32	4	4	5	4	4	6	1	1 ADC, 6 ch	1 + 2 <sup>(2)</sup>	2	1	2	2	2	-	-	1	-	SP, SO, SS, MM	I,E, H
dsPIC33EP32MC203 <sup>o</sup>	36	32	4	4	5	4	4	6	1	1 ADC, 8 ch	1 + 2 <sup>(2)</sup>	2	1	2	2	2	-	-	-	-	TL	I,E, H
dsPIC33EP32MC503 <sup>o</sup>	36	32	4	4	5	4	4	6	1	1 ADC, 8 ch	1 + 2 <sup>(2)</sup>	2	1	2	2	2	-	-	1	-	TL	I,E, H
dsPIC33EP32MC204	44	32	4	4	5	4	4	6	1	1 ADC, 9 ch	1 + 3 <sup>(2)</sup>	3	1	2	2	2	-	-	-	-	TL, ML, PT	I,E, H
dsPIC33EP32MC504	44	32	4	4	5	4	4	6	1	1 ADC, 9 ch	1 + 3 <sup>(2)</sup>	3	1	2	2	2	-	-	1	-	TL, ML, PT	I,E, H
dsPIC33EP64MC202	28	64	8	4	5	4	4	6	1	1 ADC, 6 ch	1 + 2 <sup>(2)</sup>	2	1	2	2	2	-	-	-	-	SP, SO, SS, MM	I,E, H
dsPIC33EP64MC502	28	64	8	4	5	4	4	6	1	1 ADC, 6 ch	1 + 2 <sup>(2)</sup>	2	1	2	2	2	-	-	1	-	SP, SO, SS, MM	I,E, H
dsPIC33EP64MC203 <sup>o</sup>	36	64	8	4	5	4	4	6	1	1 ADC, 8 ch	1 + 2 <sup>(2)</sup>	2	1	2	2	2	-	-	-	-	TL	I,E, H
dsPIC33EP64MC503 <sup>o</sup>	36	64	8	4	5	4	4	6	1	1 ADC, 8 ch	1 + 2 <sup>(2)</sup>	2	1	2	2	2	-	-	1	-	TL	I,E, H
dsPIC33EP64MC204	44	64	8	4	5	4	4	6	1	1 ADC, 9 ch	1 + 3 <sup>(2)</sup>	3	1	2	2	2	-	-	-	-	TL <sup>o</sup> , ML, PT	I,E, H
dsPIC33EP64MC504	44	64	8	4	5	4	4	6	1	1 ADC, 9 ch	1 + 3 <sup>(2)</sup>	3	1	2	2	2	-	-	1	-	TL <sup>o</sup> , ML, PT	I,E, H
dsPIC33EP64MC206	64	64	8	4	5	4	4	6	1	1 ADC, 16 ch	1 + 3 <sup>(2)</sup>	3	1	2	2	2	-	-	-	-	ML, PT	I,E, H
dsPIC33EP64MC506	64	64	8	4	5	4	4	6	1	1 ADC, 16 ch	1 + 3 <sup>(2)</sup>	3	1	2	2	2	-	-	1	-	ML, PT	I,E, H
dsPIC33EP128MC202	28	128	16	4	5	4	4	6	1	1 ADC, 6 ch	1 + 2 <sup>(2)</sup>	2	1	2	2	2	-	-	-	-	SP, SO, SS, MM	I,E, H
dsPIC33EP128MC502	28	128	16	4	5	4	4	6	1	1 ADC, 6 ch	1 + 2 <sup>(2)</sup>	2	1	2	2	2	-	-	1	-	SP, SO, SS, MM	I,E, H
dsPIC33EP128MC204	44	128	16	4	5	4	4	6	1	1 ADC, 9 ch	1 + 3 <sup>(2)</sup>	3	1	2	2	2	-	-	-	-	TL <sup>o</sup> , ML, PT	I,E, H
dsPIC33EP128MC504	44	128	16	4	5	4	4	6	1	1 ADC, 9 ch	1 + 3 <sup>(2)</sup>	3	1	2	2	2	-	-	1	-	TL <sup>o</sup> , ML, PT	I,E, H
dsPIC33EP128MC206	64	128	16	4	5	4	4	6	1	1 ADC, 16 ch	1 + 3 <sup>(2)</sup>	3	1	2	2	2	-	-	-	-	ML, PT	I,E, H
dsPIC33EP128MC506	64	128	16	4	5	4	4	6	1	1 ADC, 16 ch	1 + 3 <sup>(2)</sup>	3	1	2	2	2	-	-	1	-	ML, PT	I,E, H
dsPIC33EP256MC202	28	256	32	4	5	4	4	6	1	1 ADC, 6 ch	1 + 2 <sup>(2)</sup>	2	1	2	2	2	-	-	-	-	SP, SO, SS, MM	I,E, H
dsPIC33EP256MC502	28	256	32	4	5	4	4	6	1	1 ADC, 6 ch	1 + 2 <sup>(2)</sup>	2	1	2	2	2	-	-	1	-	SP, SO, SS, MM	I,E, H
dsPIC33EP256MC204	44	256	32	4	5	4	4	6	1	1 ADC, 9 ch	1 + 3 <sup>(2)</sup>	3	1	2	2	2	-	-	-	-	TL <sup>o</sup> , ML, PT	I,E, H
dsPIC33EP256MC504	44	256	32	4	5	4	4	6	1	1 ADC, 9 ch	1 + 3 <sup>(2)</sup>	3	1	2	2	2	-	-	1	-	TL <sup>o</sup> , ML, PT	I,E, H
dsPIC33EP256MC206	64	256	32	4	5	4	4	6	1	1 ADC, 16 ch	1 + 3 <sup>(2)</sup>	3	1	2	2	2	-	-	-	-	ML, PT	I,E, H
dsPIC33EP256MC506	64	256	32	4	5	4	4	6	1	1 ADC, 16 ch	1 + 3 <sup>(2)</sup>	3	1	2	2	2	-	-	1	-	ML, PT	I,E, H
dsPIC33EP512MC202	28	512	48	4	5	4	4	6	1	1 ADC, 6 ch	1 + 2 <sup>(2)</sup>	2	1	2	2	2	-	-	-	-	SO, SS, MM	I,E, H
dsPIC33EP512MC502	28	512	48	4	5	4	4	6	1	1 ADC, 6 ch	1 + 2 <sup>(2)</sup>	2	1	2	2	2	-	-	1	-	SO, SS, MM	I,E, H
dsPIC33EP512MC204	44	512	48	4	5	4	4	6	1	1 ADC, 9 ch	1 + 3 <sup>(2)</sup>	3	1	2	2	2	-	-	-	-	ML, PT	I,E, H
dsPIC33EP512MC504	44	512	48	4	5	4	4	6	1	1 ADC, 9 ch	1 + 3 <sup>(2)</sup>	3	1	2	2	2	-	-	1	-	ML, PT	I,E, H
dsPIC33EP512MC206	64	512	48	4	5	4	4	6	1	1 ADC, 16 ch	1 + 3 <sup>(2)</sup>	3	1	2	2	2	-	-	-	-	ML, PT	I,E, H
dsPIC33EP512MC506	64	512	48	4	5	4	4	6	1	1 ADC, 16 ch	1 + 3 <sup>(2)</sup>	3	1	2	2	2	-	-	1	-	ML, PT	I,E, H

# Recommended Products

## Recommended Products for Brushless DC Motors, PMSMs and ACIMs (Continued)

Device	Pins	Flash (KB)	RAM (KB)	DMA # Ch	Timer 16-bit	Input Capture	Output Compare/ Standard PWM	Motor Control PWM Ch	OEI	ADC	Analog Comparators	Op Amps	CodeGuard™ Security Segments	UART	SPI	I <sup>2</sup> C	PMP	RTCC	CAN	USB 2.0	Package	Temperature Range <sup>(a)</sup>
dsPIC33EP128GM304	44	128	16	4	9	8	8	12	2	2 ADC, 18 ch	1 + 4 <sup>(2)</sup>	4	1	4	3	2	-	-	-	-	ML, PT	I, E, H
dsPIC33EP128GM604	44	128	16	4	9	8	8	12	2	2 ADC, 18 ch	1 + 4 <sup>(2)</sup>	4	1	4	3	2	-	-	2	-	ML, PT	I, E, H
dsPIC33EP128GM306	64	128	16	4	9	8	8	12	2	2 ADC, 30 ch	1 + 4 <sup>(2)</sup>	4	1	4	3	2	1	-	-	-	ML, PT	I, E, H
dsPIC33EP128GM706	64	128	16	4	9	8	8	12	2	2 ADC, 30 ch	1 + 4 <sup>(2)</sup>	4	1	4	3	2	1	-	2	-	ML, PT	I, E, H
dsPIC33EP128GM310	100	128	16	4	9	8	8	12	2	2 ADC, 49 ch	1 + 4 <sup>(2)</sup>	4	1	4	3	2	1	-	-	-	PT, BG	I, E, H
dsPIC33EP128GM710	100	128	16	4	9	8	8	12	2	2 ADC, 49 ch	1 + 4 <sup>(2)</sup>	4	1	4	3	2	1	-	2	-	PT, BG	I, E, H
dsPIC33EP256GM304	44	256	32	4	9	8	8	12	2	2 ADC, 18 ch	1 + 4 <sup>(2)</sup>	4	1	4	3	2	-	-	-	-	ML, PT	I, E, H
dsPIC33EP256GM604	44	256	32	4	9	8	8	12	2	2 ADC, 18 ch	1 + 4 <sup>(2)</sup>	4	1	4	3	2	-	-	2	-	ML, PT	I, E, H
dsPIC33EP256GM306	64	256	32	4	9	8	8	12	2	2 ADC, 30 ch	1 + 4 <sup>(2)</sup>	4	1	4	3	2	1	-	-	-	ML, PT	I, E, H
dsPIC33EP256GM706	64	256	32	4	9	8	8	12	2	2 ADC, 30 ch	1 + 4 <sup>(2)</sup>	4	1	4	3	2	1	-	2	-	ML, PT	I, E, H
dsPIC33EP256GM310	100	256	32	4	9	8	8	12	2	2 ADC, 49 ch	1 + 4 <sup>(2)</sup>	4	1	4	3	2	1	-	-	-	PT, BG	I, E, H
dsPIC33EP256GM710	100	256	32	4	9	8	8	12	2	2 ADC, 49 ch	1 + 4 <sup>(2)</sup>	4	1	4	3	2	1	-	2	-	PT, BG	I, E, H
dsPIC33EP512GM304	44	512	48	4	9	8	8	12	2	2 ADC, 18 ch	1 + 4 <sup>(2)</sup>	4	1	4	3	2	-	-	-	-	ML, PT	I, E, H
dsPIC33EP512GM604	44	512	48	4	9	8	8	12	2	2 ADC, 18 ch	1 + 4 <sup>(2)</sup>	4	1	4	3	2	-	-	2	-	ML, PT	I, E, H
dsPIC33EP512GM306	64	512	48	4	9	8	8	12	2	2 ADC, 30 ch	1 + 4 <sup>(2)</sup>	4	1	4	3	2	1	-	-	-	ML, PT	I, E, H
dsPIC33EP512GM706	64	512	48	4	9	8	8	12	2	2 ADC, 30 ch	1 + 4 <sup>(2)</sup>	4	1	4	3	2	1	-	2	-	ML, PT	I, E, H
dsPIC33EP512GM310	100	512	48	4	9	8	8	12	2	2 ADC, 49 ch	1 + 4 <sup>(2)</sup>	4	1	4	3	2	1	-	-	-	PT, BG	I, E, H
dsPIC33EP512GM710	100	512	48	4	9	8	8	12	2	2 ADC, 49 ch	1 + 4 <sup>(2)</sup>	4	1	4	3	2	1	-	2	-	PT, BG	I, E, H
dsPIC33EV64GM002	28	64	8	4	5	4	4	6	-	1 ADC, 11 ch	1 + 4 <sup>(2)</sup>	4	1	2	2	1	-	-	-	-	SO,SS, MM	I, E, H
dsPIC33EV64GM102	28	64	8	4	5	4	4	6	-	1 ADC, 11 ch	1 + 4 <sup>(2)</sup>	4	1	2	2	1	-	-	1	-	SO,SS, MM	I, E, H
dsPIC33EV64GM004	44	64	8	4	5	4	4	6	-	1 ADC, 24 ch	1 + 4 <sup>(2)</sup>	4	1	2	2	1	-	-	-	-	ML, PT	I, E, H
dsPIC33EV64GM104	44	64	8	4	5	4	4	6	-	1 ADC, 24 ch	1 + 4 <sup>(2)</sup>	4	1	2	2	1	-	-	1	-	ML, PT	I, E, H
dsPIC33EV64GM006	64	64	8	4	5	4	4	6	-	1 ADC, 36 ch	1 + 4 <sup>(2)</sup>	4	1	2	2	1	-	-	-	-	ML, PT	I, E, H
dsPIC33EV64GM106	64	64	8	4	5	4	4	6	-	1 ADC, 36 ch	1 + 4 <sup>(2)</sup>	4	1	2	2	1	-	-	1	-	ML, PT	I, E, H
dsPIC33EV128GM002	28	128	8	4	5	4	4	6	-	1 ADC, 11 ch	1 + 4 <sup>(2)</sup>	4	1	2	2	1	-	-	-	-	SO,SS, MM	I, E, H
dsPIC33EV128GM102	28	128	8	4	5	4	4	6	-	1 ADC, 11 ch	1 + 4 <sup>(2)</sup>	4	1	2	2	1	-	-	1	-	SO,SS, MM	I, E, H
dsPIC33EV128GM004	44	128	8	4	5	4	4	6	-	1 ADC, 24 ch	1 + 4 <sup>(2)</sup>	4	1	2	2	1	-	-	-	-	ML, PT	I, E, H
dsPIC33EV128GM104	44	128	8	4	5	4	4	6	-	1 ADC, 24 ch	1 + 4 <sup>(2)</sup>	4	1	2	2	1	-	-	1	-	ML, PT	I, E, H
dsPIC33EV128GM006	64	128	8	4	5	4	4	6	-	1 ADC, 36 ch	1 + 4 <sup>(2)</sup>	4	1	2	2	1	-	-	-	-	ML, PT	I, E, H
dsPIC33EV128GM106	64	128	8	4	5	4	4	6	-	1 ADC, 36 ch	1 + 4 <sup>(2)</sup>	4	1	2	2	1	-	-	1	-	ML, PT	I, E, H
dsPIC33EV256GM002	28	256	16	4	5	4	4	6	-	1 ADC, 11 ch	1 + 4 <sup>(2)</sup>	4	1	2	2	1	-	-	-	-	SO,SS, MM	I, E, H
dsPIC33EV256GM102	28	256	16	4	5	4	4	6	-	1 ADC, 11 ch	1 + 4 <sup>(2)</sup>	4	1	2	2	1	-	-	1	-	SO,SS, MM	I, E, H
dsPIC33EV256GM004	44	256	16	4	5	4	4	6	-	1 ADC, 24 ch	1 + 4 <sup>(2)</sup>	4	1	2	2	1	-	-	-	-	ML, PT	I, E, H
dsPIC33EV256GM104	44	256	16	4	5	4	4	6	-	1 ADC, 24 ch	1 + 4 <sup>(2)</sup>	4	1	2	2	1	-	-	1	-	ML, PT	I, E, H
dsPIC33EV256GM006	64	256	16	4	5	4	4	6	-	1 ADC, 36 ch	1 + 4 <sup>(2)</sup>	4	1	2	2	1	-	-	-	-	ML, PT	I, E, H
dsPIC33EV256GM106	64	256	16	4	5	4	4	6	-	1 ADC, 36 ch	1 + 4 <sup>(2)</sup>	4	1	2	2	1	-	-	1	-	ML, PT	I, E, H
PIC32MK0512MCF064	64	512	128	21	14	16	16	16	6	7 ADC, 26 ch	5	4	-	6	6		Yes	Yes	4	1	PT, MR	I, E
PIC32MK1024MCF064	64	1024	256	21	14	16	16	16	6	7 ADC, 26 ch	5	4	-	6	6		Yes	Yes	4	1	PT, MR	I, E
PIC32MK0512MCF064	100	512	128	21	14	16	16	16	6	7 ADC, 42 ch	5	4	-	6	6		Yes	Yes	4	2	PT	I, E
PIC32MK0512MCF064	100	1024	256	21	14	16	16	16	6	7 ADC, 42 ch	5	4	-	6	6		Yes	Yes	4	2	PT	I, E
ATSAMC20N	100	256	32	6	8	8	8	12	1	2 ADC, 20 ch	4	-	-	8 <sup>0</sup>	8 <sup>0</sup>	8 <sup>0</sup>	No	Yes	No	No	PT	I, E
ATSAMC20J	64/56	256	32	6	8	8	8	12	1	2 ADC, 20 ch	4	-	-	6 <sup>0</sup>	6 <sup>0</sup>	6 <sup>0</sup>	No	Yes	No	No	PT	I, E
ATSAMC20G	48	256	32	6	8	8	8	12	1	2 ADC, 20 ch	4	-	-	6 <sup>0</sup>	6 <sup>0</sup>	6 <sup>0</sup>	No	Yes	No	No	PT	I, E
ATSAMC20E	32	256	32	6	8	8	8	12	1	2 ADC, 20 ch	4	-	-	4 <sup>0</sup>	4 <sup>*</sup>	4 <sup>*</sup>	No	Yes	No	No	PT	I, E
ATSAMC21N	100	256	32	12	8	8	8	12	1	2 ADC, 20 ch	4	-	-	8 <sup>0</sup>	8 <sup>0</sup>	8 <sup>0</sup>	No	Yes	x2 CAN-FD	No	PT	I, E
ATSAMC21J	64/56	256	32	12	8	8	8	12	1	2 ADC, 20 ch	4	-	-	6 <sup>0</sup>	6 <sup>0</sup>	6 <sup>0</sup>	No	Yes	x2 CAN-FC	No	PT	I, E

## Recommended Products for Brushless DC Motors, PMSMs and ACIMs (Continued)

Device	Pins	Flash (KB)	RAM (KB)	DMA # Ch	Timer 16-bit	Input Capture	Output Compare/ Standard PWM	Motor Control PWM Ch	OEI	ADC	Analog Comparators	Op Amps	CodeGuard™ Security Segments	UART	SPI	I <sup>2</sup> C	PMP	RTCC	CAN	USB 2.0	Package	Temperature Range <sup>(a)</sup>
ATSAMC21G	48	256	32	12	8	8	8	12	1	2 ADC, 20 ch	4	-	-	6 <sup>9</sup>	6 <sup>9</sup>	6 <sup>9</sup>	No	Yes	x2 CAN-FC	No	PT	I, E
ATSAMC21E	32	256	32	12	8	8	8	12	1	2 ADC, 20 ch	4	-	-	4 <sup>9</sup>	4 <sup>9</sup>	4 <sup>9</sup>	No	Yes	x2 CAN-FC	No	PT	I, E
ATSAMD21J	64	256	32	12	5	3	3	12	1	1 ADC, 20 ch	2	-	-	6 <sup>9</sup>	6 <sup>9</sup>	6 <sup>9</sup>	No	Yes	No	1	-	-
ATSAMD21G	48	256	32	12	5	3	3	12	1	1 ADC, 20 ch	2	-	-	6 <sup>9</sup>	6 <sup>9</sup>	6 <sup>9</sup>	No	Yes	No	1	-	-
ATSAMD21E	32	256	32	12	5	3	3	12	1	1 ADC, 20 ch	2	-	-	6 <sup>9</sup>	6 <sup>9</sup>	6 <sup>9</sup>	No	Yes	No	1	-	-
ATSAMD21G16L	48	64	8	12	5	13	-	12	-	1 ADC, 18 ch	4	-	-	6 <sup>9</sup>	6 <sup>9</sup>	6 <sup>9</sup>	No	Yes	No	No	-	-
ATSAMD21E15L	32	32	4	12	5	13	-	12	-	1 ADC, 14 ch	4	-	-	6 <sup>9</sup>	6 <sup>9</sup>	6 <sup>9</sup>	No	Yes	No	No	-	-
ATSAMD21E16L	32	64	8	12	5	13	-	12	-	1 ADC, 14 ch	4	-	-	6 <sup>9</sup>	6 <sup>9</sup>	6 <sup>9</sup>	No	Yes	No	No	-	-

## Training Classes

Motor Type	Class Title	Language	Recording Date	Duration
Brushed DC	Brushed DC Motor Basics	English	09/18/2008	14 min.
Stepper	Stepper Motors Part 1: Types of Stepper Motors	English	09/14/2007	19 min.
	Stepper Motors Part 2: Stepper Motor Control	English	09/14/2007	17 min.
BLDC	Sensorless BLDC Motor Control Using a Majority Function	English	04/29/2008	19 min.
PMSM	Sensorless Field-Oriented Control for Permanent Magnet Synchronous Motors	English	03/30/2007	30 min.
ACIM	Sensorless Field-Oriented Control (FOC) for AC Induction Motors	English	01/21/2008	23 min.

## Applications Notes

### Motor Type/Algorithm Versus MCU Family

Motor Type	Algorithm	PIC16 Family	PIC18 Family	dsPIC® DSC Family
Stepper Motor	Full- and Half-Stepping	AN906, AN907	-	AN1307
	Micro-Stepping	-	AN822	AN1307
Brushed DC Motor	Uni-Directional	AN905	-	-
	Bi-Directional	AN893	-	-
	Servo Motor	AN532, AN696	AN696	-
BLDC and PMSM	Sensored	AN857, AN885, AN1779, AN2049	AN899	AN957
	Sensored Sinusoidal	-	-	AN1017
	Sensorless BEMF	AN857, AN1175, AN1305	AN970	AN901, AN992
	Sensorless Filtered BEMF with Majority Detect	-	-	AN1160
	Sensorless Dual-Shunt FOC with SMO Estimator and Field Weakening	-	-	AN1078
	Sensorless Dual-Shunt FOC with SMO and PFC	-	-	AN1208
	Sensorless Dual-Shunt FOC with PLL Estimator and Field Weakening	-	-	AN1292
	Sensorless Single-Shunt FOC with SMO Estimator and Field Weakening	-	-	AN1299
ACIM	Open Loop V/F	AN887, AN889, AN955, AN967, AN1660	AN900, AN843	AN984
	Closed Loop Vector Control	-	-	AN980
	Sensorless Dual-Shunt FOC with PLL Estimator	-	-	AN1162
	Sensorless Dual-Shunt FOC with PLL Estimator and Field Weakening	-	-	AN1206
Other	PFC	-	-	AN1106
	Appliance Class B (IEC 60730)	-	AN1229	AN1229
	Motor Control Sensor Feedback Circuits	AN894	AN894	AN894
	MOSFET Driver Selection	AN898	AN898	AN898
	Current Sensing Circuit Concepts and Fundamentals	AN1332	AN1332	AN1332



## Motor Control Application Notes by Motor Type

Motor Type	App Note	Description
Stepper Motor	AN822	Stepper Motor Micro-stepping with PIC18C452
	AN906	Stepper Motor Control Using the PIC16F684
	AN907	Stepper Motor Fundamentals
	AN1307	Stepper Motor Control Using the dsPIC® DSC
Brushed DC Motor	AN696	PIC18CXXX/PIC16CXXX DC Servomotor Applications
	AN893	Low-Cost Bi-directional Brushed DC Motor Control Using the PIC16F684
	AN905	Brushed DC Motor Fundamentals
BLDC and PMSM	AN857	Brushless DC Motor Control Made Easy
	AN885	Brushless DC (BLDC) Motor Fundamentals
	AN899	Brushless DC Motor Control Using PIC18FXX31 MCUs
	AN901	Sensorless Control of BLDC Motor Using dsPIC30F6010
	AN992	Sensorless Control of BLDC Motor Using dsPIC30F2010
	AN957	Sensored Control of BLDC Motor Using dsPIC30F2010
	AN970	Using the PIC18F2431 for Sensorless BLDC Motor Control
	AN1017	Sinusoidal Control of PMSMs with dsPIC30F With Four Quadrant Control
	AN1078	Dual Shunt Sensorless FOC for PMSM with SMO Estimator and Field Weakening
	AN1160	Sensorless BLDC Control with Back-EMF Filtering Using a Majority Function
	AN1175	Sensorless Brushless DC Motor Control with PIC16
	AN1208	Integrated Power Factor Correction and Sensorless Field-Oriented Control System
	AN1292	Dual Shunt Sensorless FOC for PMSM with PLL Estimator and Field Weakening
	AN1299	Single Shunt Sensorless FOC for PMSM with SMO Estimator and Field Weakening
AN1305	Sensorless 3-Phase Brushless Motor Control with the PIC16FXXX	
ACIM	AN843	Speed-Control of 3-Phase Induction Motor Using PIC18 Microcontrollers
	AN887	AC Induction Motor Fundamentals
	AN889	VF Control of 3-Phase Induction Motors Using PIC16F7X7 Microcontrollers
	AN900	Controlling 3-Phase AC Induction Motors Using the PIC18F4431
	AN908	Using the dsPIC30F for Vector Control of an ACIM
	AN955	VF Control of 3-Phase Induction Motor Using Space Vector Modulation
	AN967	Bidirectional VF Control of Single and 3-Phase Induction Motor Using Space Vector Modulation
	AN984	Introduction to ACIM Control Using the dsPIC30F
	AN1162	Sensorless Field-Oriented Control (FOC) of an ACIM
AN1206	Sensorless Field-Oriented Control (FOC) of an ACIM Using Field Weakening	
Other	AN894	Motor Control Sensor Feedback Circuits
	AN898	Determining MOSFET Driver Needs for Motor Drive Applications
	AN1106	Power Factor Correction on dsPIC DSC
	AN1229	Meeting IEC 60730 Class B Compliance with dsPIC DSC
	AN1332	Current Sensing Circuit Concepts and Fundamentals

Note 1: dsPIC33 devices feature one or two user-selectable 1.1 Msps 10-bit ADC (4 S & H) or 500 kpsps 12-bit ADC (1 S & H).

2: Op amps can be configured as comparators.

3: I = Industrial Temperature Range (–40°C to +85°C), E = Extended Temperature Range (–40°C to +125°C), H = High Temperature Range (–40°C to +140°C).

⚡ Check [www.microchip.com](http://www.microchip.com) for availability.

## MPLAB X IDE

### Universal and Integrated Tool Set

MPLAB X IDE is a single, universal graphical user interface for Microchip and third-party software and hardware development tools. It is the industry's only IDE to support an entire portfolio of 8-bit, 16-bit and 32-bit PIC MCUs, dsPIC DSCs and memory devices.



MPLAB X IDE supports Microchip's compilers, emulators, debuggers and starter kits, as well as many third-party tools. Moving between all of your favorite Microchip tools and upgrading from software simulators to hardware debugging and programming tools is simple with this IDE's seamless user interface.

### Powerful Yet User-Friendly Interface

With complete project management, visual call graphs, a configurable watch window and a feature-rich editor that includes code completion, context menus and a task navigator, MPLAB X IDE is flexible and friendly enough for new users.

MPLAB X IDE is also fully equipped for the needs of experienced users with the ability to support multiple tools on multiple projects with multiple configurations and simultaneous debugging.

### Open-Source Platform

Based on the NetBeans™ Platform, MPLAB X IDE supports a host of free software components and plug-ins from the NetBeans community for high-performance application development customized to your needs. In addition to local file history, MPLAB X IDE is also compatible with revision control plug-ins and Bugzilla.

### Cross-Platform

Using MPLAB X IDE, you can run your favorite toolset and develop your next embedded application on Windows®, Linux® or Mac OS® operating systems.

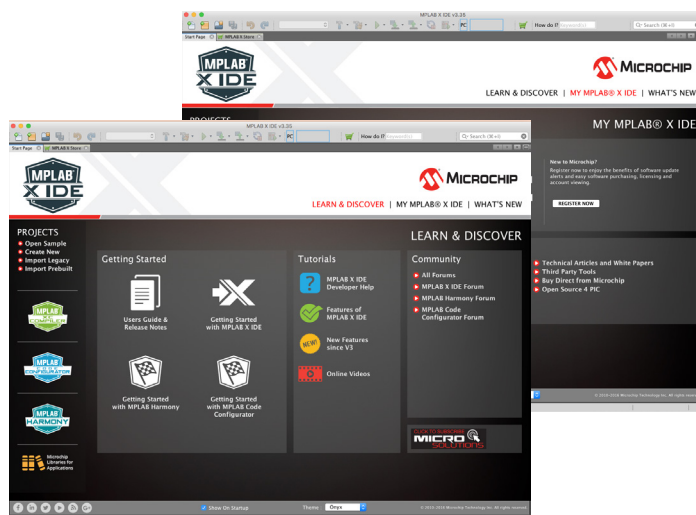

## MPLAB XC16 Compiler for PIC24 MCUs and dsPIC DSCs

The MPLAB XC16 Compiler includes a complete ANSI C standard library, including string manipulation, dynamic memory allocation, data conversion, timekeeping and math libraries. The compiler has a powerful code optimizer. Other 16-bit MCU compilers generate as much as 165% more code for the same application.



The assembler comes with the MPLAB XC Compiler and may be used with the compiler or as an assembler. It is a full-featured macro assembler. User-defined macros, conditional assembly and a variety of assembler directives make the assembler a power code generation tool.

Download a full-featured, time-restricted evaluation version of the MPLAB XC16 Compiler for PIC24 MCUs or dsPIC DSCs from [www.microchip.com/compilers](http://www.microchip.com/compilers).

## MPLAB SIM Software Simulator

The MPLAB SIM Software Simulator is a full-featured, cycle-accurate software simulator available for MPLAB X IDE. In addition to simulating the CPU and the instruction set, it also supports key peripherals.

## MPLAB X IDE Plug-Ins

These software plug-in tools included with MPLAB X IDE assist with the development of motor control applications:

### Data Monitor and Control Interface (DMCI)

Provides a customizable GUI to input and adjust software motor parameters using sliders and switches. Four customizable output plots can be used to show a graphical history of control variables so that the motor dynamic response can be analyzed. This tool is useful for tweaking software parameters and visualizing historical data during debug sessions. Most motor control application note software comes with a setup file to automatically configure DMCI for the application.

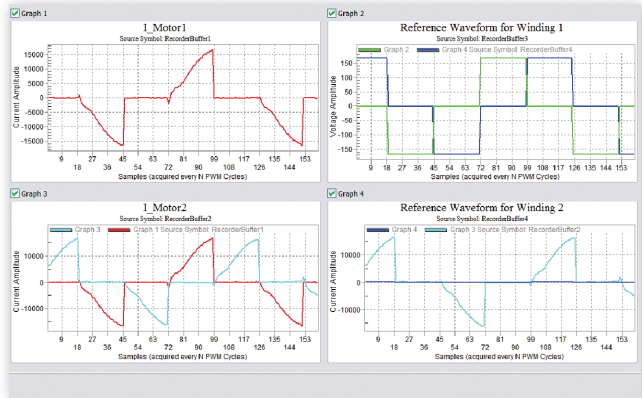
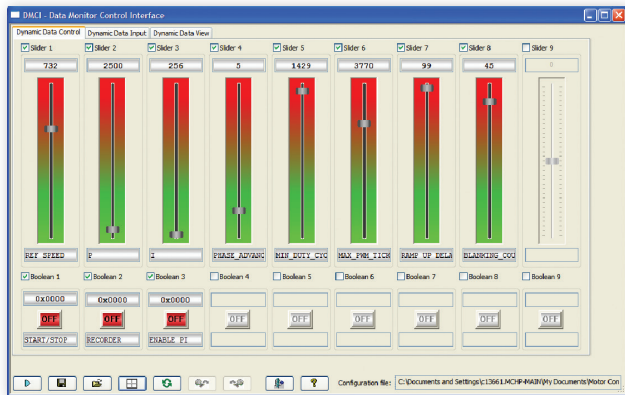
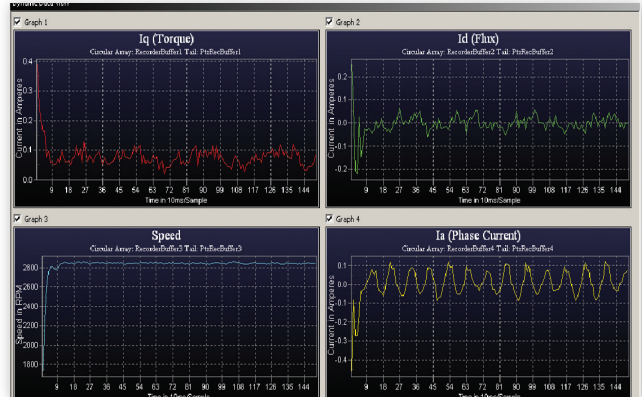
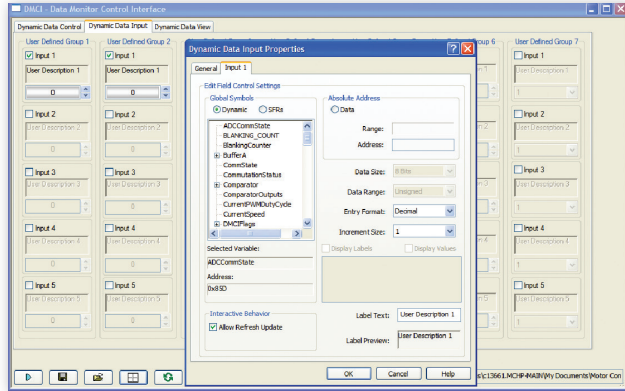

### Real-Time Data Monitor (RTDM)

Make a change to a software parameter and see the effect immediately without stopping the motor. A serial USB or UART cable supports bi-directional data transfers between the host PC and the MCU/DSC. This is configured within DMCI and most motor control application note software comes with a setup file to automatically configure RTDM for the application.

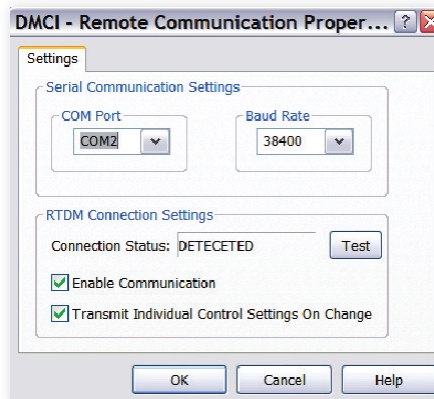
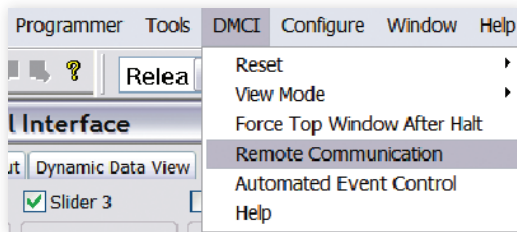

## Support

Microchip is committed to supporting its customers in developing products faster and more efficiently. We maintain a worldwide network of field applications engineers and technical support ready to provide product and system assistance. For more information, please visit [www.microchip.com](http://www.microchip.com):

- Technical Support: [www.microchip.com/support](http://www.microchip.com/support)
- Evaluation samples of any Microchip device: [www.microchip.com/sample](http://www.microchip.com/sample)
- Knowledge base and peer help: [www.microchip.com/forums](http://www.microchip.com/forums)
- Sales and Global Distribution: [www.microchip.com/sales](http://www.microchip.com/sales)

## Training

If additional training interests you, Microchip offers several resources including in-depth technical training and reference material, self-paced tutorials and significant online resources.

- Overview of Technical Training Resources: [www.microchip.com/training](http://www.microchip.com/training)
- MASTERS Conferences: [www.microchip.com/masters](http://www.microchip.com/masters)
- Developer Help Website: [www.microchip.com/developerhelp](http://www.microchip.com/developerhelp)
- Technical Training Centers: [www.microchip.com/seminars](http://www.microchip.com/seminars)

## Sales Office Listing

### AMERICAS

**Atlanta, GA**  
Tel: 678-957-9614

**Austin, TX**  
Tel: 512-257-3370

**Boston, MA**  
Tel: 774-760-0087

**Chandler, AZ (HQ)**  
Tel: 480-792-7200

**Chicago, IL**  
Tel: 630-285-0071

**Dallas, TX**  
Tel: 972-818-7423

**Detroit, MI**  
Tel: 248-848-4000

**Houston, TX**  
Tel: 281-894-5983

**Indianapolis, IN**  
Tel: 317-773-8323  
Tel: 317-536-2380

**Los Angeles, CA**  
Tel: 949-462-9523  
Tel: 951-273-7800

**Raleigh, NC**  
Tel: 919-844-7510

**New York, NY**  
Tel: 631-435-6000

**San Jose, CA**  
Tel: 408-735-9110  
Tel: 408-436-4270

**Canada - Toronto**  
Tel: 905-695-1980

### EUROPE

**Austria - Wels**  
Tel: 43-7242-2244-39

**Denmark - Copenhagen**  
Tel: 45-4450-2828

**Finland - Espoo**  
Tel: 358-9-4520-820

**France - Paris**  
Tel: 33-1-69-53-63-20

**France - Saint Cloud**  
Tel: 33-1-30-60-70-00

**Germany - Garching**  
Tel: 49-8931-9700

**Germany - Haan**  
Tel: 49-2129-3766-400

**Germany - Heilbronn**  
Tel: 49-7131-67-3636

**Germany - Karlsruhe**  
Tel: 49-721-62537-0

**Germany - Munich**  
Tel: 49-89-627-144-0

**Germany - Rosenheim**  
Tel: 49-8031-354-560

### EUROPE

**Israel - Ra'anana**  
Tel: 972-9-744-7705

**Italy - Milan**  
Tel: 39-0331-742611

**Italy - Padova**  
Tel: 39-049-7625286

**Netherlands - Drunen**  
Tel: 31-416-690399

**Norway - Trondheim**  
Tel: 47-7289-7561

**Poland - Warsaw**  
Tel: 48-22-3325737

**Romania - Bucharest**  
Tel: 40-21-407-87-50

**Spain - Madrid**  
Tel: 49-91-708-08-90

**Sweden - Gothenberg**  
Tel: 46-31-704-60-40

**UK - Wokingham**  
Tel: 44-118-921-5800

### ASIA/PACIFIC

**Australia - Sydney**  
Tel: 61-2-9868-6733

**China - Beijing**  
Tel: 86-10-8569-7000

**China - Chengdu**  
Tel: 86-28-8665-5511

**China - Chongqing**  
Tel: 86-23-8980-9588

**China - Dongguan**  
Tel: 86-769-8702-9880

**China - Guangzhou**  
Tel: 86-20-8755-8029

**China - Hangzhou**  
Tel: 86-571-8792-8115

**China - Hong Kong SAR**  
Tel: 852-2943-5100

**China - Nanjing**  
Tel: 86-25-8473-2460

**China - Qingdao**  
Tel: 86-532-8502-7355

**China - Shanghai**  
Tel: 86-21-3326-8000

**China - Shenyang**  
Tel: 86-24-2334-2829

**China - Shenzhen**  
Tel: 86-755-8864-2200

**China - Wuhan**  
Tel: 86-27-5980-5300

**China - Xiamen**  
Tel: 86-592-2388138

**China - Xian**  
Tel: 86-29-8833-7252

### ASIA/PACIFIC

**China - Zhuhai**  
Tel: 86-756-321-0040

**India - Bangalore**  
Tel: 91-80-3090-4444

**India - New Delhi**  
Tel: 91-11-4160-8631

**India - Pune**  
Tel: 91-20-3019-1500

**Japan - Osaka**  
Tel: 81-6-6152-7160

**Japan - Tokyo**  
Tel: 81-3-6880-3770

**Korea - Daegu**  
Tel: 82-53-744-4301

**Korea - Seoul**  
Tel: 82-2-554-7200

**Malaysia - Kuala Lumpur**  
Tel: 60-3-6201-9857

**Malaysia - Penang**  
Tel: 60-4-227-8870

**Philippines - Manila**  
Tel: 63-2-634-9065

**Singapore**  
Tel: 65-6334-8870

**Taiwan - Hsin Chu**  
Tel: 886-3-577-8366

**Taiwan - Kaohsiung**  
Tel: 886-7-213-7830

**Taiwan - Taipei**  
Tel: 886-2-2508-8600

**Thailand - Bangkok**  
Tel: 66-2-694-1351

10/28/16



[www.microchip.com](http://www.microchip.com)

Microchip Technology Inc. | 2355 W. Chandler Blvd. | Chandler AZ, 85224-6199