

Assembled SMD Power Inductors – WPZ Series

Operating Temp. : -40°C~+125°C(Including self-heating)



FEATURES

- High saturation characteristic core for large saturation current and low loss
- Closed magnetic circuit design reduces leakage flux
- High precision DCR
- Halogen free, RoHS compliant

APPLICATIONS

- Server, desktop computer, notebook
- Graphics, memory
- Industrial equipment, telecom base station

PRODUCT IDENTIFICATION

WPZ
①

1008
②

7
③

S
④

1
⑤

R12
⑥

K
⑦

T
⑧

□□□
⑨

①	Type
WPZ	SMD Power Inductor

②	External Dimensions(LxW) [mm]
0404	4.0x4.1
0505	5.2x5.2
0606	6.4x6.4
0707	7.0x7.3
0905	9.0x5.0
0906	9.6x6.4
0907	9.5x7.5
1004	10.2x4.0
1006	10.0x6.15
1007	10.7x7.0
1008	10.4x8.0
1010	10.0x10.0
1106	10.6x6.3
1107	11.0x7.4
1206	12x6.0
1308	13.5x8.5
1313	13.7x12.8
1612	15.3x11.3
1811	18.0x11.3

③	External Height Dimensions(H) [mm]
1	H<1.5
2	1.5≤H<2.5
3	2.5≤H<3.5
4	3.5≤H<4.5
5	4.5≤H<5.5
6	5.5≤H<6.5
7	6.5≤H<7.5
8	7.5≤H<8.5
9	8.5≤H<9.5
A	9.5≤H<10.5
B	10.5≤H<11.5
C	11.5≤H<12.5
D	12.5≤H<13.5
E	13.5≤H<14.5
F	14.5≤H<15.5
G	15.5≤H<16.5

④	Magnetic Core Material
B	High Saturation
S	Low Loss
F	High Frequency
N	NiZn
M	Alloy

PRODUCT IDENTIFICATION

⑤ Number of Turns	
1	1 Ring
2	2 Ring
3	3 Ring

⑦ Inductance Tolerance	
K	±10%
L	±15%
M	±20%

⑥ Nominal Inductance	
Example	Nominal Value
70N	70nH
R12	120nH

⑧ Packing	
T	Tape & Reel

⑨ Design Code	
□□□	Design Code
* Standard product is blank	

SHAPE AND DIMENSIONS — 2 Pins

Fig.1

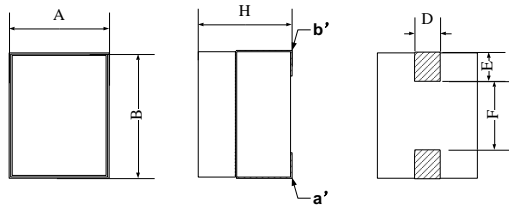

Fig.2

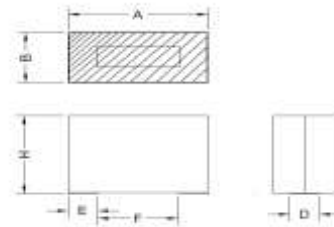

Fig.3

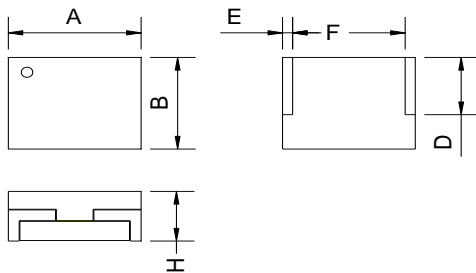

Fig.4

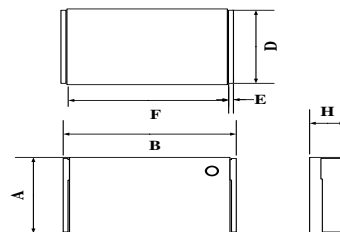

Fig.5

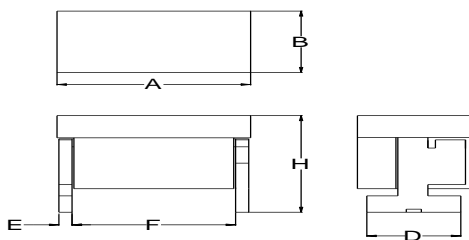

Fig.6

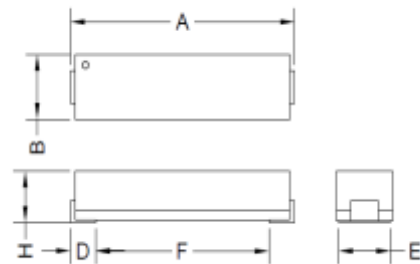
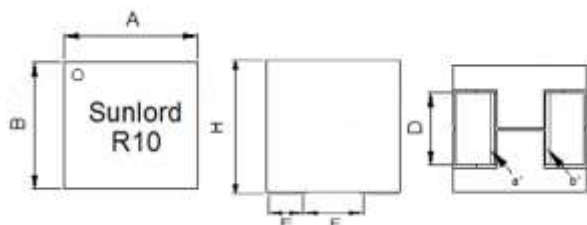
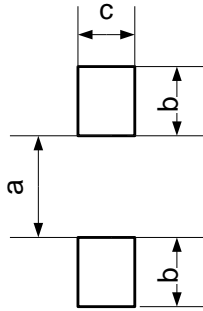

Fig.7



SHAPE AND DIMENSIONS — 2 Pins

Recommended Land Pattern (Typ.)



Unit: mm

Series	Shape	A Max.	B Max.	H Max.	D	E	F	a Typ.	b Typ.	c Typ.
WPZ04044S1	Fig.1	4.0	4.1	4.0	1.0±0.2	1.2±0.3	/	0.7	1.8	1.4
WPZ05057S1	Fig.1	5.2	5.2	6.5	2.0±0.2	0.7±0.2	3.7±0.3	3.2	1.15	2.5
WPZ0606AF1	Fig.7	6.5	6.5	10	3.7±0.2	1.75±0.2	2.65±0.2	2.05	2.35	4.1
WPZ07074N1	Fig.1	6.8	7.3	4.2	1.0±0.2	1.9±0.4	3.2±1.0	2.6	2.5	1.4
WPZ07074S1	Fig.1	6.8	7.3	3.8	3.0±0.2	1.6±0.3	3.8 Typ.	3.2	2.2	3.4
WPZ07075S1	Fig.1	7.0	7.0	5.0	2.5±0.25	1.5±0.3	3.9 Typ.	3.3	2.1	3.0
WPZ0707BB1	Fig.7	7.0	6.9/6.7	11	3.7±0.2	1.8±0.2	2.8±0.3	2.3	2.3	4.2
WPZ09068S1	Fig.2	9.6	6.4	8.1	2.5±0.2	2.14±0.2	4.4 Typ.	3.8	3.1	2.54
WPZ09059F1	Fig.2	9.0	5.2/5.0	9.5	2.4±0.2	2.5±0.2	/	3.4	2.9	3.0
WPZ0906AB1	Fig.2	9.6	6.6/6.4	10.1	3.15±0.2	2.8±0.2	3.8 Typ.	3.4	3.3	3.6
WPZ0906AS1	Fig.2	9.6	6.6/6.4	10.1	3.15±0.2	2.8±0.2	3.8 Typ.	3.4	3.3	3.6
WPZ0906AF1	Fig.2	9.6	6.6/6.4	10.1	2.6±0.2	2.8±0.2	3.8 Typ.	3.4	3.3	3.6
WPZ09074S1	Fig.3	9.5	7.5	4.0	4.5±0.2	0.65±0.2	7.3 Min.	7.1	1.25	4.9
WPZ09079S1	Fig.3	9.5	7.5	9.0	4.3 Typ.	1.2 Typ.	6.2 Typ.	5.8	1.8	4.7
WPZ10042M1	Fig.6	10.2	4.0	2.4	2.0±0.3	3.0±0.3	6.2 Typ.	5.6	2.6	3.4
WPZ1006CB1	Fig.2	10.0	6.0	12.0	2.45±0.3	2.95±0.3	3.65±0.5	3.15	3.3	3.3
WPZ1006CS1	Fig.2	10.0	6.15/6.0	12.0	2.45±0.3	2.95±0.3	3.65±0.5	3.05	3.55	2.85
WPZ10075B1	Fig.1	7.0	10.2	5.0	2.5±0.1	1.9±0.2	6.0Typ.	5.4	2.5	3.0
WPZ10075S1	Fig.1	7.0	10.25	5.2	2.54±0.1	2.03±0.2	5.94±0.2	5.08	2.8	3.05
WPZ10075M1	Fig.1	7.0	10.7	5.0	2.54±0.2	2.3±0.2	5.9 Typ.	5.3	2.9	2.94
WPZ1007AS1	Fig.2	10.0	7.0	10.0	2.2±0.25	2.3±0.3	4.1± 0.3	3.5	3.1	2.6
WPZ1007CS1	Fig.7	10.7	7.9/7.7/7.5	12	3.1±0.2	2.8±0.3	4.4±0.3	3.7	3.4	3.5
WPZ10087S1	Fig.1	8.0	10.3	7.0	2.3±0.2	3.0±0.2	4.0 Typ.	3.4	3.6	2.7
WPZ10087B1	Fig.1	8.0	10.4	7.5	2.25±0.2	2.54±0.2	5.12 Typ.	4.7	3.0	2.5
WPZ10088S1	Fig.1	8.0	10.4	8.2	2.1±0.1	2.54±0.2	4.86 Typ.	4.26	3.14	2.5
WPZ11068S1	Fig.5	10.6	6.3	8.1	5.0±0.2	0.7±0.1	8.7Min.	8.4	1.3	5.6
WPZ11077S1	Fig.1	7.4	11.0	7.7	1.9±0.3	2.6±0.3	5.5 Typ.	4.9	3.2	2.3
WPZ13083S1	Fig.4	8.55	13.55	3.0	8.15±0.2	0.50±0.1	12.85±0.2	11.75	1.1	8.7
WPZ13138S1	Fig.1	12.8	13.7	8.1	6.5 Typ.	2.7 Typ.	7.8 Typ.	7.2	3.2	6.9

SPECIFICATIONS

Part Number	Inductance	L Test Condition	DC Resistance	Saturation Current	Heat Rating Current	
Units	nH	/	mΩ	A	A	
Symbol	L	/	DCR	Isat	Irms	
WPZ04044S122NMT	22±20%	@100kHz, 1V	0.30±10%	40	48	
WPZ04044S150NKT	50±10%			35		
WPZ04044S165NKT	65±10%			30		
WPZ04044S1R10KT	100±10%			17		
WPZ05057S160NMT	55±20%	@100kHz, 1V	0.25±20%	70	50	
WPZ05057S180NMT	80±20%			50		
WPZ05057S1R10MT	100±20%			40		
WPZ05057S1R11MT	110±20%			36		
WPZ05057S1R15MT	150±20%		25			
WPZ0606AF170NKT	70±10%	@800kHz, 0.1V	0.17±10%	120	70	
WPZ0606AF1R10KT	100±10%			85		
WPZ0606AF1R12KT	120±10%			70		
WPZ0606AF1R15KT	150±10%			56		
WPZ07074N1R10MT	100±20%	@100kHz, 1V	0.5 Max.	20	15	
WPZ07074S160NMT	60±20%		0.19 Max.	51	30	
WPZ07074S1R10MT	100±20%			34		
WPZ07075S160NMT	60±20%		0.32±9.4%	70	37	
WPZ07075S170NMT	72±20%			58		
WPZ07075S1R10MT	105±20%			46		
WPZ07075S1R15MT	150±20%			34		
WPZ0707BB155NLT	55±15%		@100kHz, 1V	0.145±10%	155	76
WPZ0707BB170NKT	70±10%				134	
WPZ0707BB1R10KT	100±10%				93	
WPZ0707BB1R12KT	120±10%				76	
WPZ0707BB1R15KT	150±10%				60	
WPZ0707BB1R22KT	220±10%				42	
WPZ0707BB1R33KT	330±10%			28		
WPZ09068S1R10KT	100±10%	@100kHz, 0.1V	0.29±5%	94	51	
WPZ09068S1R12KT	120±10%			79		
WPZ09068S1R15KT	150±10%			65		
WPZ09068S1R18KT	180±10%			55		
WPZ09068S1R22KT	220±10%			44		
WPZ09068S1R28KT	280±10%			34		
WPZ09068S1R30KT	300±10%			32.5		
WPZ09059F190NKT	90±10%	@500kHz, 0.1V	0.125±10%	90	63	
WPZ09059F1R10KT	100±10%			80		
WPZ09059F1R12KT	120±10%			72		
WPZ09059F1R15KT	150±10%			58		
WPZ09059F1R18KT	180±10%			49		
WPZ09059F1R21KT	210±10%			38		
WPZ09059F1R24KT	240±10%			33		
WPZ09059F1R27KT	270±10%			30		
WPZ09059F1R33KT	330±10%		23			
WPZ0906AB170NKT	70±10%	@800kHz, 0.1V	0.12 Max. (0.10 Typ.)	145	84	
WPZ0906AB1R10KT	100±10%			108		
WPZ0906AB1R12KT	120±10%			85		
WPZ0906AB1R15KT	150±10%			67		
WPZ0906AB1R18KT	180±10%			56		
WPZ0906AB1R22KT	220±10%			46		
WPZ0906AB1R28KT	280±10%		36			

SPECIFICATIONS

Part Number	Inductance	L Test Condition	DC Resistance	Saturation Current	Heat Rating Current
Units	nH	/	mΩ	A	A
Symbol	L	/	DCR	Isat	Irms
WPZ0906AS170NKT	70±10%	@100kHz, 0.1V	0.12 Max. (0.10 Typ.)	120	84
WPZ0906AS1R10KT	100±10%			93	
WPZ0906AS1R12KT	120±10%			70	
WPZ0906AS1R15KT	150±10%			55	
WPZ0906AS1R18KT	180±10%			46	
WPZ0906AS1R22KT	220±10%			38	
WPZ0906AS1R28KT	280±10%			30	
WPZ0906AF170NKT	70±10%			120	
WPZ0906AF1R10KT	100±10%			93	
WPZ0906AF1R12KT	120±10%			70	
WPZ0906AF1R15KT	150±10%			55	
WPZ0906AF1R18KT	180±10%			46	
WPZ0906AF1R22KT	220±10%			38	
WPZ0906AF1R28KT	280±10%			30	
WPZ09074S170NLT	70±15%	@800kHz, 0.1V	0.32±10%	78	39
WPZ09074S1R10LT	100±15%			55	
WPZ09074S1R14LT	140±15%			39	
WPZ09074S1R15LT	150±15%			33	
WPZ09074S1R18LT	175±15%			28	
WPZ09079S1R10LT	100±15%	@800kHz, 1V	0.20 Max. (0.17 Typ.)	80	50
WPZ09079S1R12LT	120±15%			66	
WPZ09079S1R15LT	150±15%			53	
WPZ09079S1R18LT	180±15%			44	
WPZ09079S1R22LT	220±15%			36	
WPZ09079S1R28LT	280±15%			28	
WPZ09079S1R30LT	300±15%	26			
WPZ10042M175NKT	75±10%	@1MHz, 1V	0.35 Max.	70	35
WPZ1006CB170NLT	70±15%	@100kHz, 1V	0.125±10%	175	70
WPZ1006CB180NLT	80±15%			155	
WPZ1006CB1R10LT	100±15%			125	
WPZ1006CB1R12LT	120±15%			105	
WPZ1006CB1R14LT	135±15%			92	
WPZ1006CB1R15LT	150±15%			83	
WPZ1006CB1R22LT	220±15%			52	
WPZ1006CB1R25LT	250±15%			46	
WPZ1006CB1R33LT	330±15%			35	
WPZ1006CS170NLT	70±15%			152	
WPZ1006CS180NLT	80±15%			134	
WPZ1006CS1R10LT	100±15%			108	
WPZ1006CS1R12LT	120±15%			91	
WPZ1006CS1R14LT	135±15%			80	
WPZ1006CS1R15LT	150±15%			72	
WPZ1006CS1R22LT	220±15%			45	
WPZ1006CS1R25LT	250±15%			40	
WPZ1006CS1R33LT	330±15%			30	

SPECIFICATIONS

Part Number	Inductance	L Test Condition	DC Resistance	Saturation Current	Heat Rating Current
Units	nH	/	mΩ	A	A
Symbol	L	/	DCR	Isat	Irms
WPZ10075B1R12KT	120±10%	@100kHz, 1V	0.35±10%	61	31
WPZ10075B1R15KT	150±10%			49	
WPZ10075B1R20KT	200±10%			37	
WPZ10075B1R22KT	220±10%			32	
WPZ10075B1R30KT	300±10%			21	
WPZ10075S170NKT	70±10%		0.1375 Max.	85	40
WPZ10075S1R10KT	100±10%			60	
WPZ10075S1R12KT	120±10%			50	
WPZ10075S1R15KT	150±10%			40	
WPZ10075S1R20KT	200±10%			30	
WPZ10075S1R30KT	300±10%		19		
WPZ10075M170NLT	70±15%		0.23±10%	130	68
WPZ10075M1R10LT	100±15%			96	
WPZ10075M1R12LT	120±15%			80	
WPZ10075M1R16LT	160±15%			60	
WPZ1007AS170NLT	70±15%		0.17±10%	165	68
WPZ1007AS1R10LT	100±15%			135	
WPZ1007AS1R12LT	120±15%			107	
WPZ1007AS1R15LT	150±15%			92	
WPZ1007AS1R20LT	200±15%			68	
WPZ1007AS1R22LT	220±15%			62	
WPZ1007AS1R33LT	330±15%		37		
WPZ1007CS170NKT	70±10%		0.150±10%	194	75
WPZ1007CS1R10KT	100±10%			136	
WPZ1007CS1R12KT	120±10%			113	
WPZ1007CS1R15KT	150±10%			90	
WPZ1007CS1R18KT	180±10%			75	
WPZ1007CS1R22KT	220±10%			61	
WPZ1007CS1R27KT	270±10%			51	
WPZ1007CS1R33KT	330±10%			41	
WPZ1007CS1R47KT	470±10%			29	
WPZ10087S1R10KT	100±10%			96	
WPZ10087S1R12KT	120±10%		80	60	
WPZ10087S1R15KT	150±10%		72		
WPZ10087S1R17KT	170±10%		58		
WPZ10087S1R22KT	220±10%		46		
WPZ10087S1R30KT	300±10%		32		
WPZ10087S1R33KT	330±10%		28		
WPZ10087B1R10KT	100±10%		108	61	
WPZ10087B1R12KT	115±10%		94		
WPZ10087B1R15KT	150±10%		76		
WPZ10087B1R17KT	175±10%		66		
WPZ10087B1R22KT	215±10%	50			
WPZ10087B1R23KT	230±10%	48			
WPZ10087B1R27KT	270±10%	40			
WPZ10087B1R30KT	300±10%	35			

SPECIFICATIONS

Part Number	Inductance	L Test Condition	DC Resistance	Saturation Current	Heat Rating Current
Units	nH	/	mΩ	A	A
Symbol	L	/	DCR	Isat	Irms
WPZ10088S180NKT	80±10%	@100kHz, 0.1V	0.18±5%	130	68
WPZ10088S182NKT	82±10%			126	
WPZ10088S1R10KT	100±10%			113	
WPZ10088S1R12KT	120±10%			95	
WPZ10088S1R15KT	150±10%			78	
WPZ10088S1R18KT	180±10%			62	
WPZ10088S1R22KT	220±10%			52	
WPZ10088S1R27KT	270±10%			41	
WPZ10088S1R30KT	300±10%			35	
WPZ10088S1R33KT	330±10%			33	
WPZ11068S1R10KT	100±10%			@300kHz, 0.1V	
WPZ11068S1R12KT	120±10%	78			
WPZ11068S1R16KT	160±10%	60			
WPZ11068S1R20KT	200±10%	45			
WPZ11077S170NKT	70±10%	@100kHz, 1V	0.29±10%	150	39
WPZ11077S1R12KT	120±10%			95	
WPZ11077S1R15KT	150±10%			80	
WPZ11077S1R17KT	170±10%			70	
WPZ11077S1R20KT	200±10%			60	
WPZ11077S1R23KT	230±10%			50	
WPZ11077S1R30KT	300±10%			37	
WPZ11077S1R40KT	400±10%			25	
WPZ11077S1R50KT	500±10%			18	
WPZ11077S1R51KT	510±10%			18	
WPZ13083S1R11KT	110±10%	@100kHz, 0.1V	0.45±10%	65	30
WPZ13083S1R15KT	145±10%			50	
WPZ13083S1R21KT	210±10%			34	
WPZ13083S1R26KT	260±10%			27	
WPZ13083S1R32KT	320±10%			22	
WPZ13138S1R11KT	110±10%	@100kHz, 1V	0.19±10%	140	68
WPZ13138S1R15KT	150±10%			100	
WPZ13138S1R18KT	180±10%			85	
WPZ13138S1R21KT	210±10%			80	
WPZ13138S1R26KT	260±10%			60	
WPZ13138S1R32KT	320±10%			45	
WPZ13138S1R36KT	360±10%			40	
WPZ13138S1R44KT	440±10%			35	
WPZ13138S1R50KT	500±10%	28			

※1: All test data is referenced to 25°C ambient;

※2: Isat: DC current at which the inductance drops approximate 20% from its value without current;

※3: Irms: DC current that causes the temperature rise (ΔT) from 25°C ambient when two coils connected in series, ΔT is approximate 40°C.

SHAPE AND DIMENSIONS — 3 Pins

Fig.1

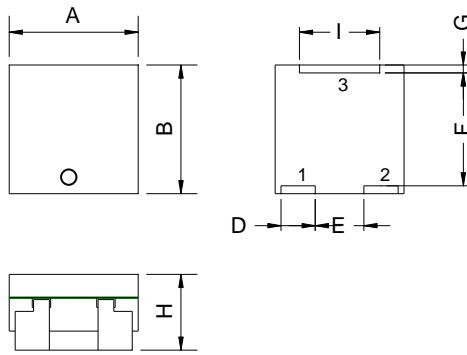

Fig.2

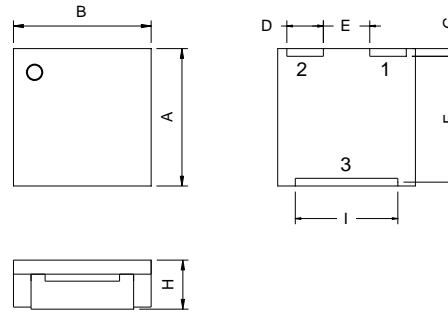
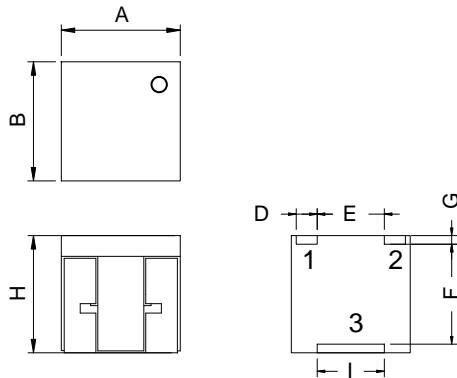

Fig.3



Recommended Land Pattern (Typ.)

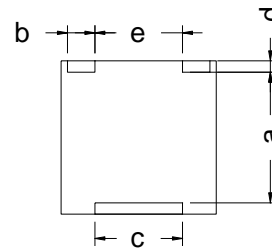
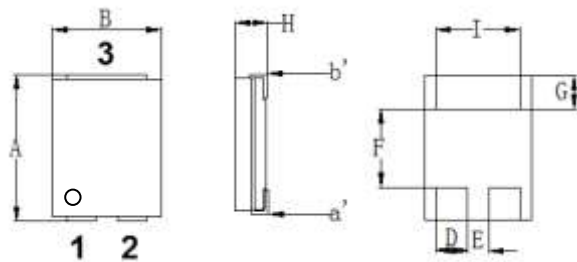
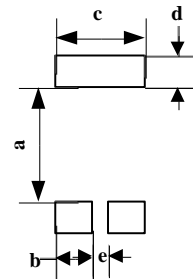

Fig.4



Recommended Land Pattern (Typ.)



Unit: mm

Series	Shape	A	B	H	D	E	F	G	I	a	b	c Typ.	d	e
WPZ06065	Fig.3	6.4	6.4	5.3	1.82	2.9	5.5	0.55	3.7	54.7	2.2	3.9	1.0	2.1
WPZ10103	Fig.2	10.0	10.0	3.35	2.8	3.3	8.9	0.6	7.6	8.0	3.2	7.8	1.25	2.6
WPZ10106	Fig.1	10.0	10.0	6.0	2.7	4.0	8.6	0.7	6.2	8.1	3.0	6.5	1.2	3.2
WPZ16123	Fig.4	15.3	11.3	3.0	3.2	2.65	10.3	2.7	8.65	8.6	4.0	9.5	3.9	1.5
WPZ18113S	Fig.4	18.0	11.4	3.0	/	/	/	/	/	11.6	3.7	9.0	3.2	/

EQUIVALENT CIRCUIT

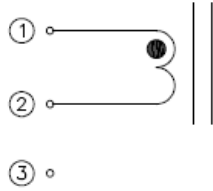

SPECIFICATIONS

Part Number	Inductance (pin1-2)	L Test Condition	DC Resistance (pin1-2)	Saturation Current (pin1-2)	Heat Rating Current (pin1-2)
Units	nH	/	mΩ	A	A
Symbol	L	/	DCR	Isat	Irms
WPZ06065S1R10KT	100±10%	@1MHz, 1V	0.4±12.5%	50	24
WPZ06065S1R12KT	120±10%			41	
WPZ06065S1R15KT	150±10%			33	
WPZ06065S1R20KT	200±10%			25	
WPZ10103S1R10LT	100±15%		0.45±15%	79	31
WPZ10103S1R15LT	150±15%			52	
WPZ10103S1R22LT	220±15%			36	
WPZ10103S1R30LT	300±15%		0.66±10%	26	20
WPZ10106S1R10KT	100±10%			120	
WPZ10106S1R20KT	200±10%			60	
WPZ10106S1R22KT	220±10%			54	
WPZ10106S1R30KT	300±10%			43	
WPZ10106S1R45KT	450±10%			29	
WPZ10106S1R50KT	500±10%			26	
WPZ16123S1R16KT	145~185		@300KHz, 1V	0.66 Max.	55
WPZ18113S1R25KT	250±10%	30		25	

SHAPE AND DIMENSIONS — 4 Pins

Fig.1

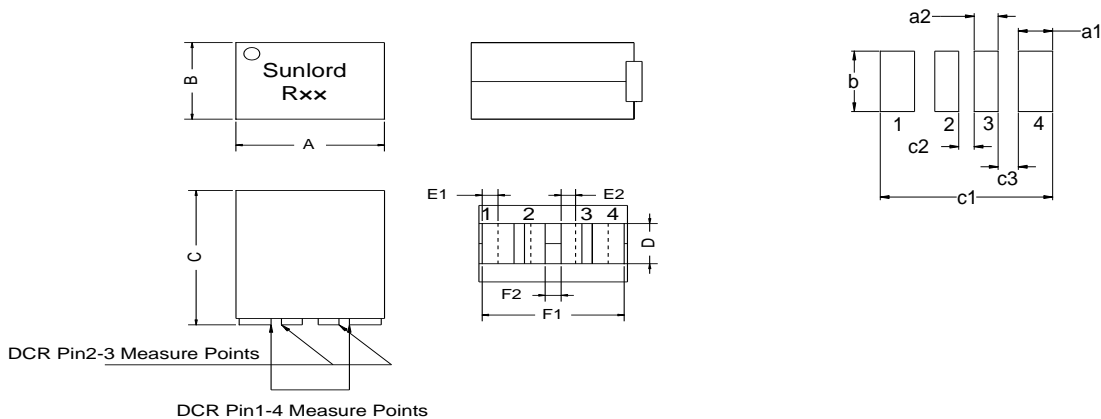

SHAPE AND DIMENSIONS — 4 Pins

Fig.2

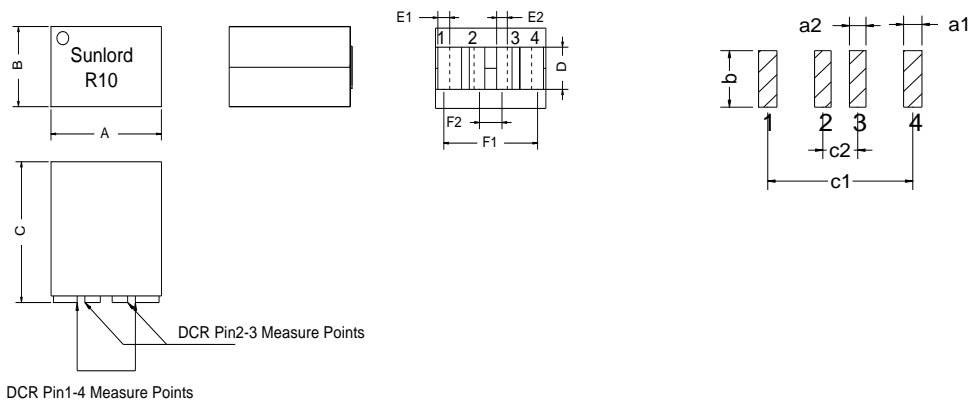
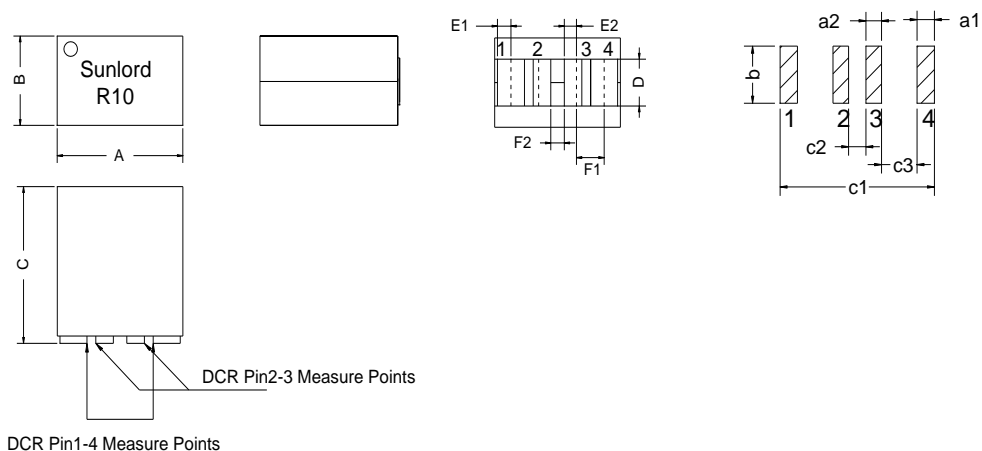

Fig.3



Unit: mm

Series	Shape	A	B	C	D	E1	E2	F1	F2	a1	a2	b	c1	c2	c3
		Max.	Max.	Max.	Max.	Max.	Max.	Max.	Max.	Typ.	Typ.	Typ.	Typ.	Typ.	Typ.
WPZ0906AS2	Fig.1	9.6	6.4	10	3.4	1.8	1.3	9.75	1.9	2.15	1.45	3.6	10.1	/	/
WPZ0906BS2	Fig.1	9.6	6.4	11.4	3.25	1.65	1.06	9.55	1.78	1.85	1.26	3.55	9.75	0.98	1.275
WPZ1206BS2	Fig.2	12.0	6.0	11.1	2.75	1.6	1.45	10.6	3.15	1.8	1.65	2.85	10.1	2.65	/
WPZ1206CF2	Fig.3	12.0	6.0	12.0	3.1	1.86	1.5	2.52	1.9	2.16	1.8	3.2	12.15	1.0	1.62



Fig.4

Δf: Clearance between terminal and the surface of plate must be 0.1mm Max. when coil is placed on a flat plate. (Refer to Fig.4)

SPECIFICATIONS

Part Number	Inductance	L Test Condition	DC Resistance		Saturation Current	Heat Rating Current		Hi-Pot	Lk/OCL		
							@25°C				
Units	nH	/	mΩ		A	A		/	/		
Symbol	L(Pin1-4)	/	Pin1-4	Pin2-3	Isat (Pin1-4)	Irms (Pin1-4)	Irms (Pin2-3)	Pri(1.4)-Sec(2.3)	Pin1-4 (Shorted Pin2-3)		
WPZ0906AS2R10LT	100±15%	@500KHz, 0.25V	0.125±10%	0.45±10%	92	75	39	100Vdc 2s 2mA	/		
WPZ0906AS2R12LT	120±15%				75						
WPZ0906AS2R15LT	150±15%				60						
WPZ0906BS270NLT	70±15%	@100KHz, 0.1V	0.125±10%	0.60±10%	149	75	/			200Vdc 2s 2mA	20%*L Max.
WPZ0906BS280NLT	80±15%				131						
WPZ0906BS2R10LT	100±15%				105						
WPZ0906BS2R11LT	110±15%				95						
WPZ0906BS2R12LT	120±15%				87						
WPZ0906BS2R15LT	150±15%				70						
WPZ0906BS2R17LT	170±15%				61						
WPZ1206BS270NLT	70±15%	@100KHz, 1V	0.143Max. (0.13Typ.)	0.429Max. (0.39Typ.)	157	78	45			100Vdc 2s 2mA	10nH Max.
WPZ1206BS2R10LT	100±15%				112						
WPZ1206BS2R12LT	120±15%				94						
WPZ1206BS2R15LT	150±15%				74						
WPZ1206BS2R17LT	170±15%				64						
WPZ1206BS2R20LT	200±15%	55									
WPZ1206CF270NLT	70±15%	@600KHz, 1V	0.125Max. (0.11Typ.)	0.45Max. (0.38 Typ.)	155	84	51	100Vdc 2s 2mA	/		
WPZ1206CF2R10LT	100±15%				110						
WPZ1206CF2R12LT	120±15%				92						
WPZ1206CF2R15LT	150±15%				70						
WPZ1206CF2R18LT	180±15%				65						

※1: All test data is referenced to 25°C ambient;

※2: Isat: DC current at which the inductance drops approximate 20% from its value without current;

※3: Irms: DC current that causes the temperature rise (ΔT) from 25°C ambient when two coils connected in series, ΔT is approximate 40°C.

TYPICAL ELECTRICAL CHARACTERISTICS

WPZ04044S1 Series

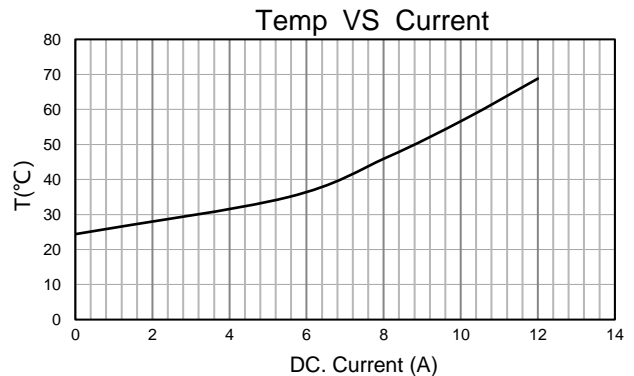
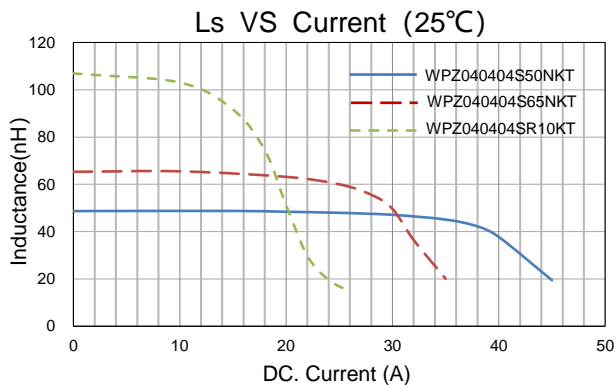

TYPICAL ELECTRICAL CHARACTERISTICS

WPZ05057S1 Series

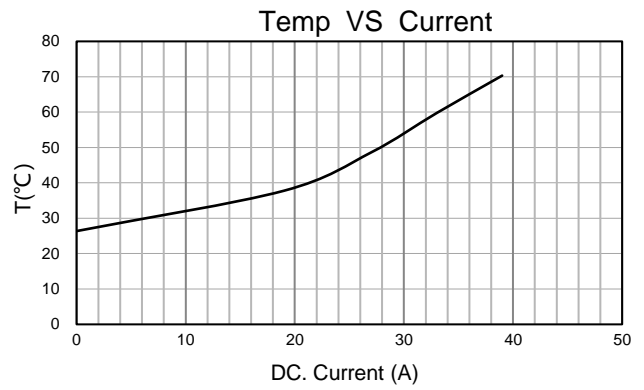
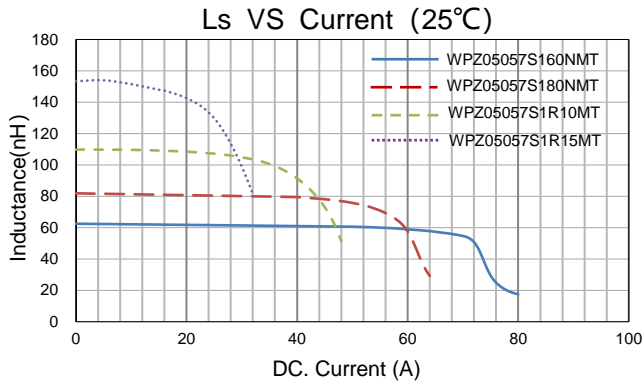

WPZ0606AF1 Series

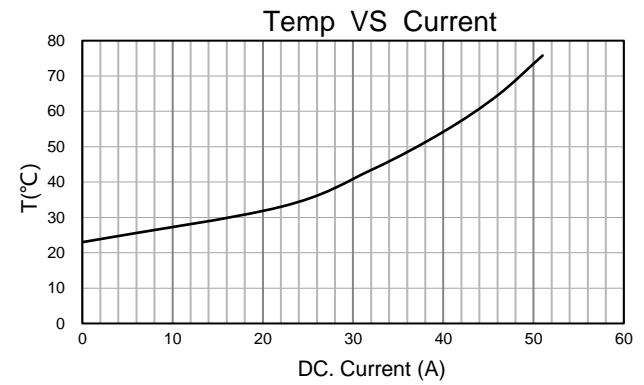
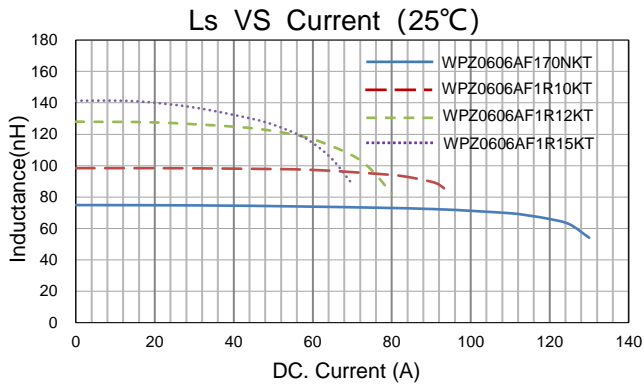

WPZ07074N1 Series

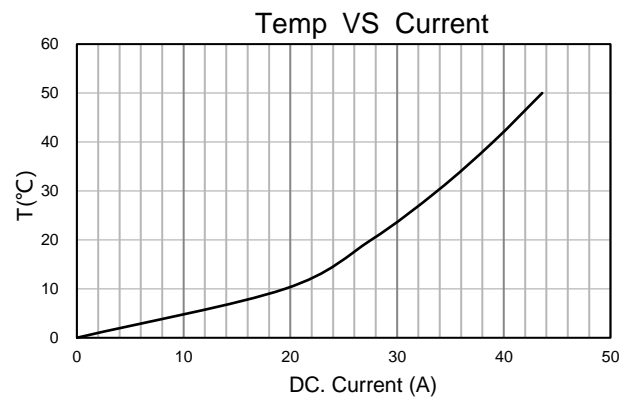
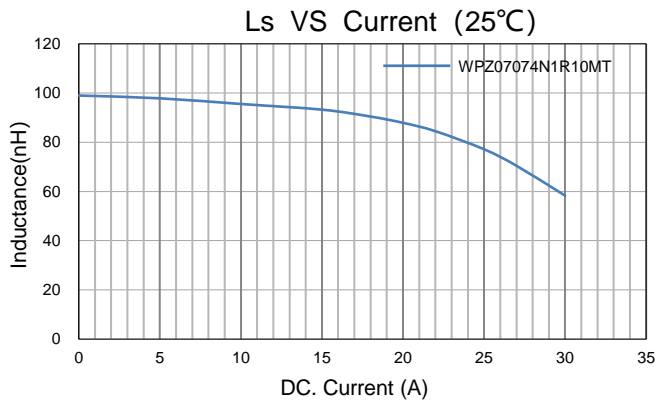

WPZ07074S1 Series

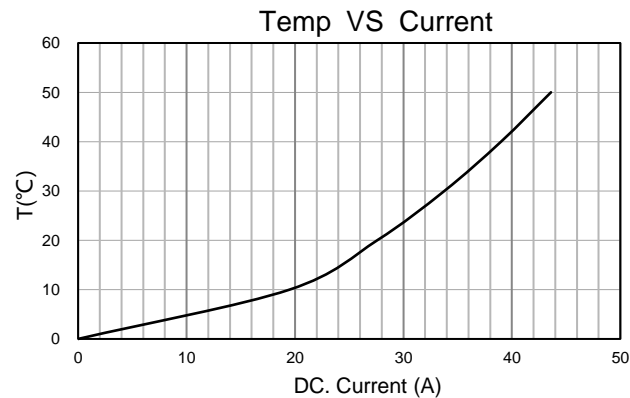
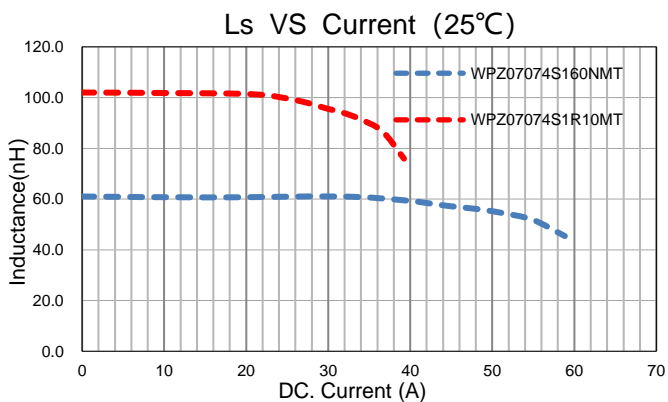

TYPICAL ELECTRICAL CHARACTERISTICS

WPZ07075S1 Series

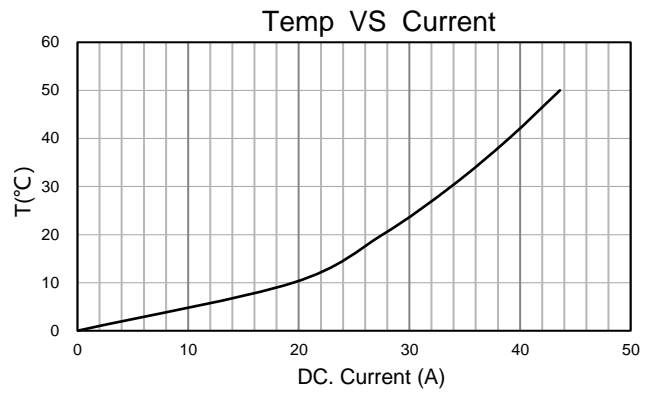
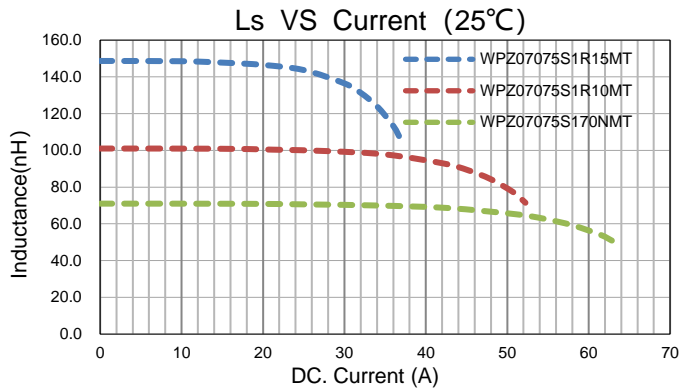

WPZ0707BB1 Series

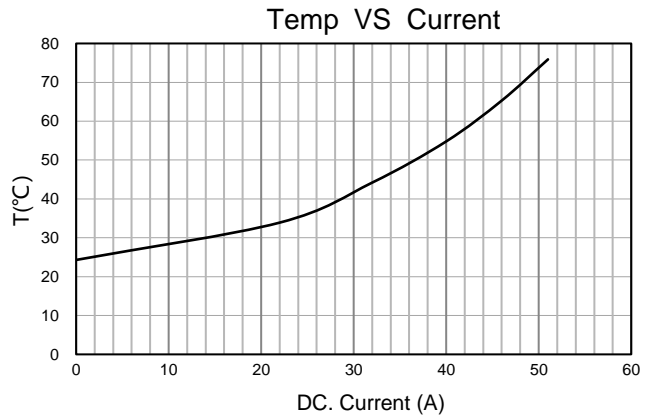
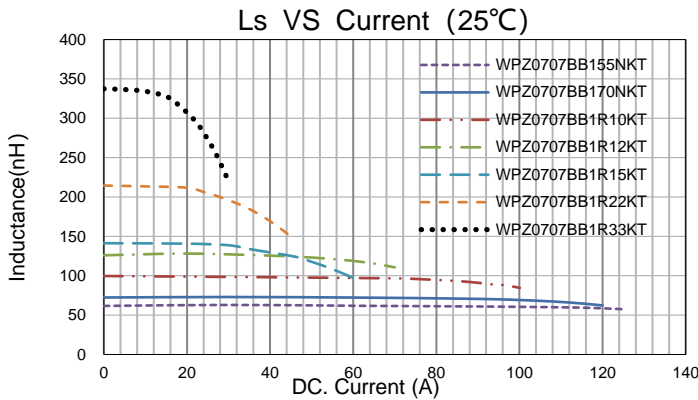

WPZ09068S1 Series

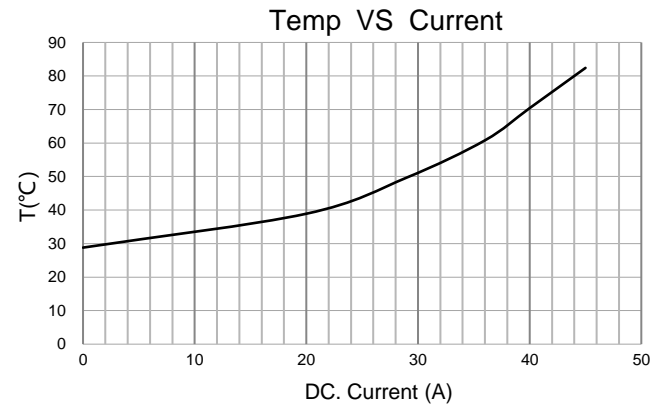
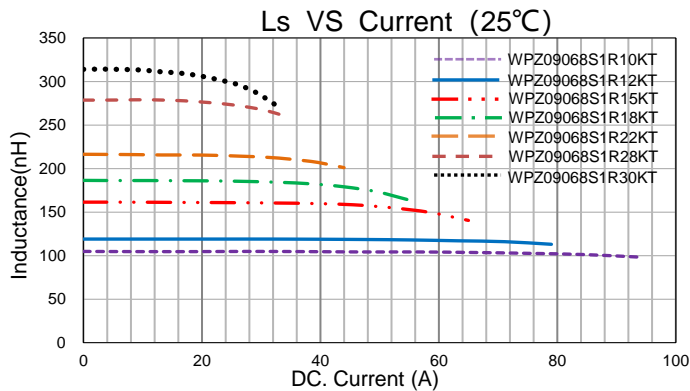

WPZ09059F1 Series

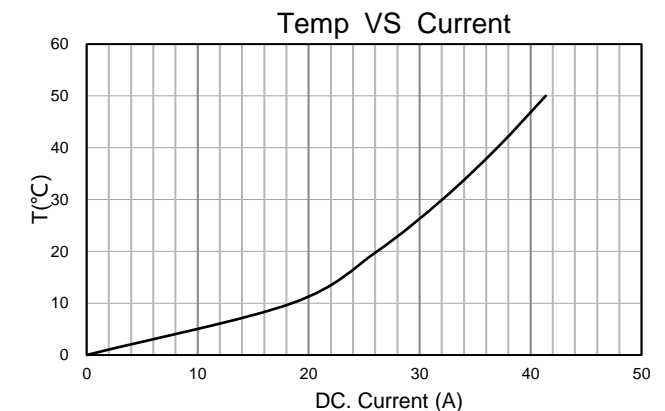
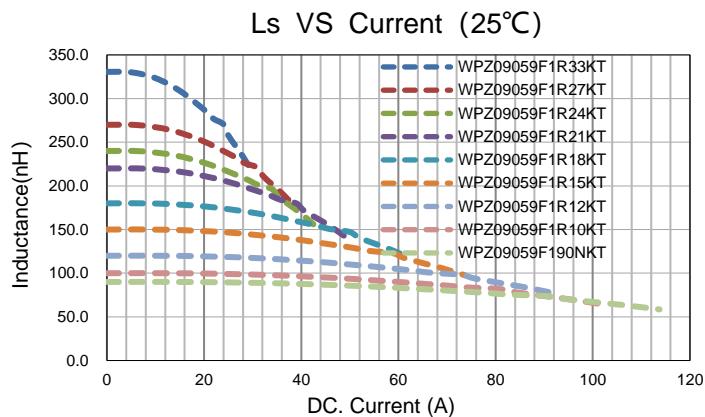

TYPICAL ELECTRICAL CHARACTERISTICS

WPZ0906AB1 Series

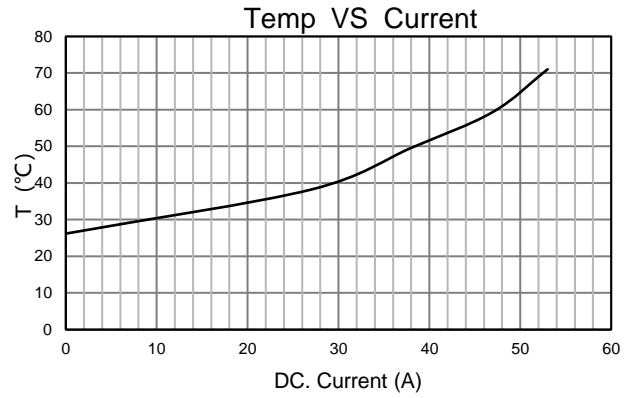
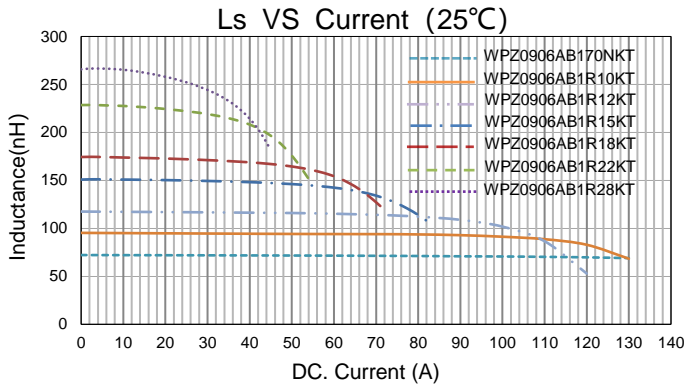

WPZ0906AS1 Series

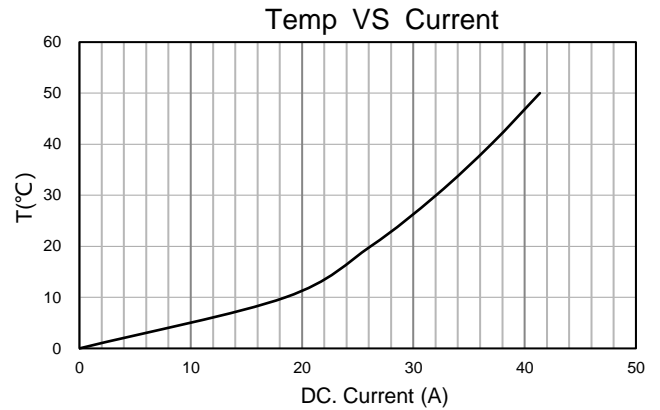
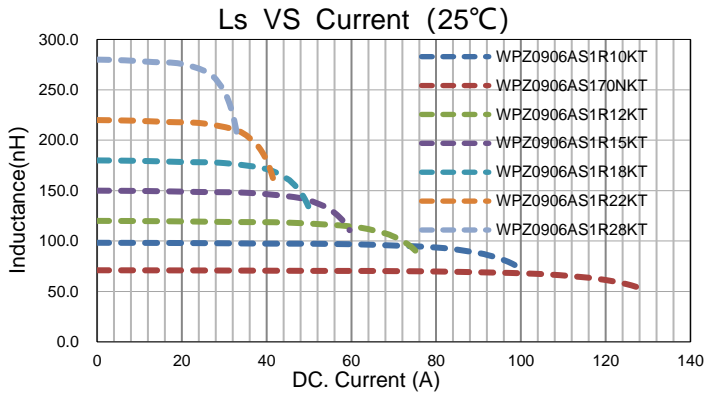

WPZ0906AF1 Series

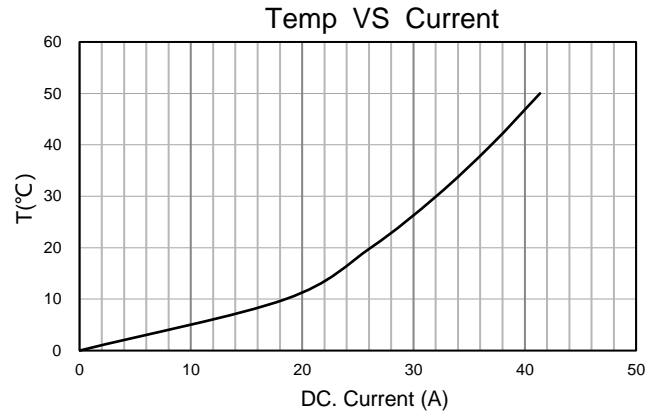
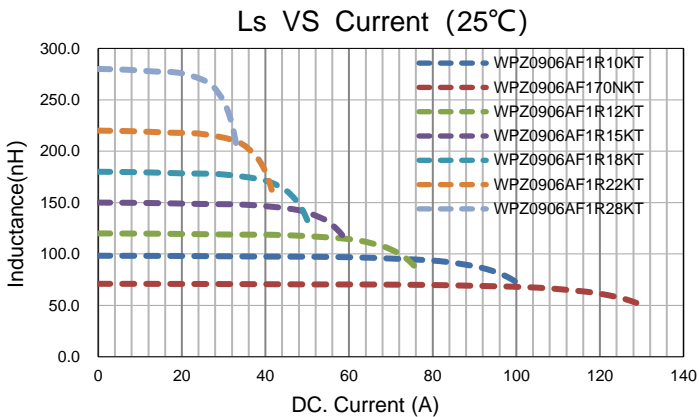

WPZ09074S1 Series

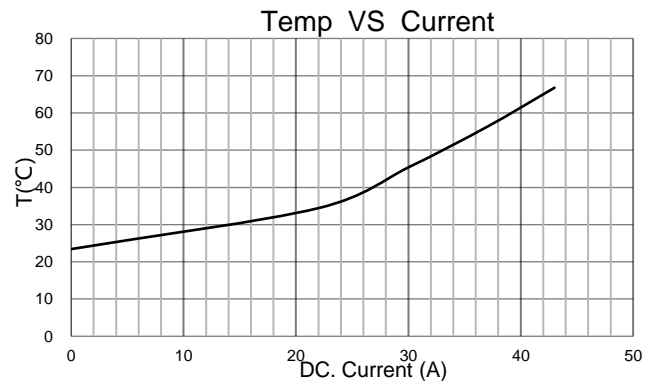
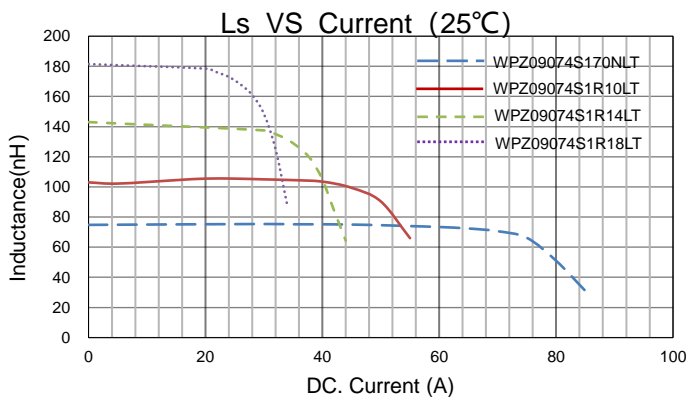

TYPICAL ELECTRICAL CHARACTERISTICS

WPZ09079S1 Series

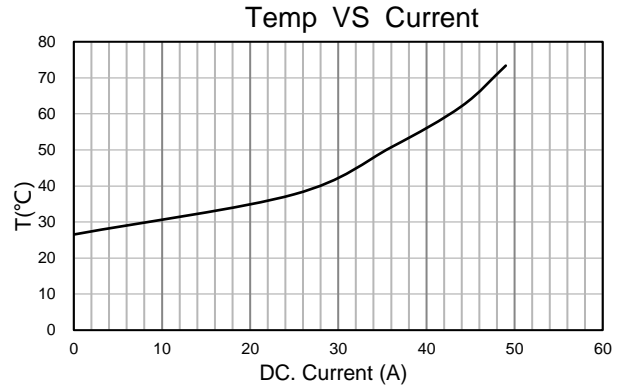
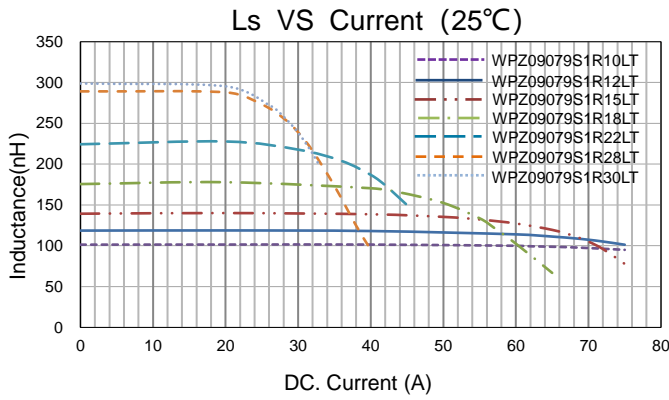

WPZ10042M1 Series

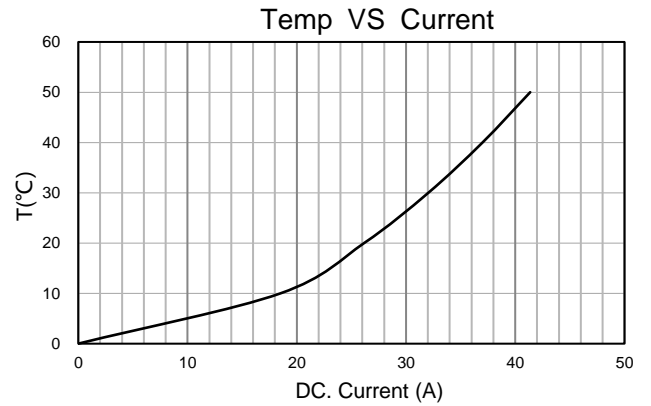
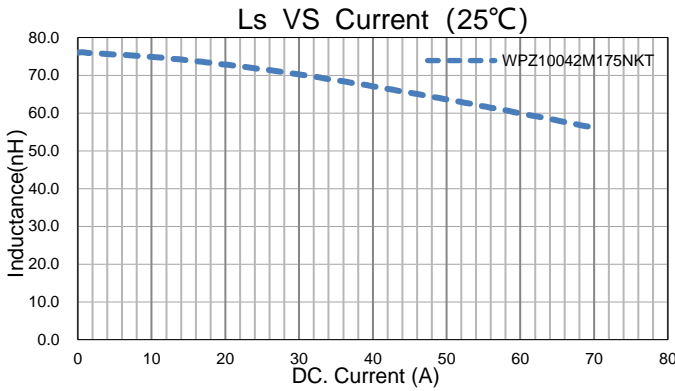

WPZ1006CB1 Series

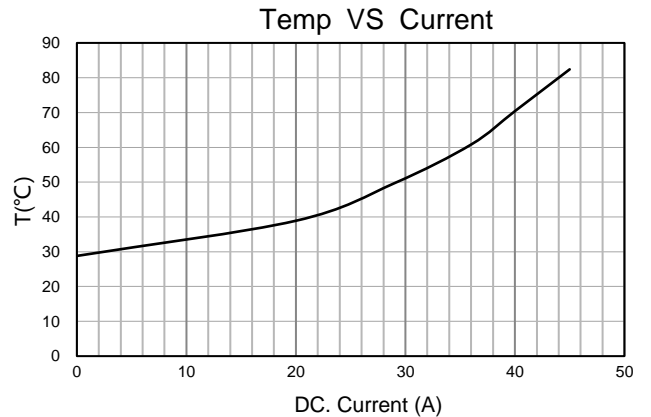
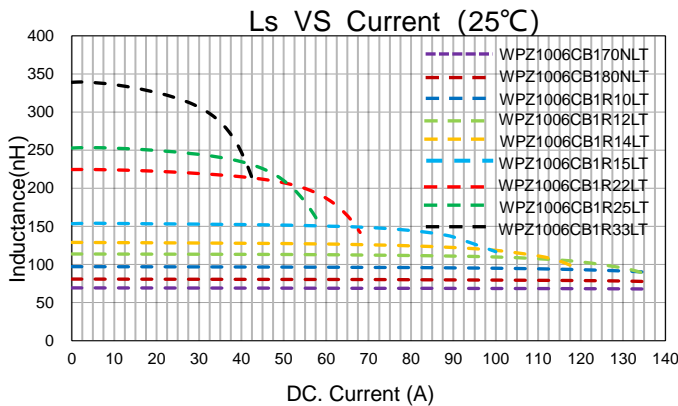

WPZ1006CS1 Series

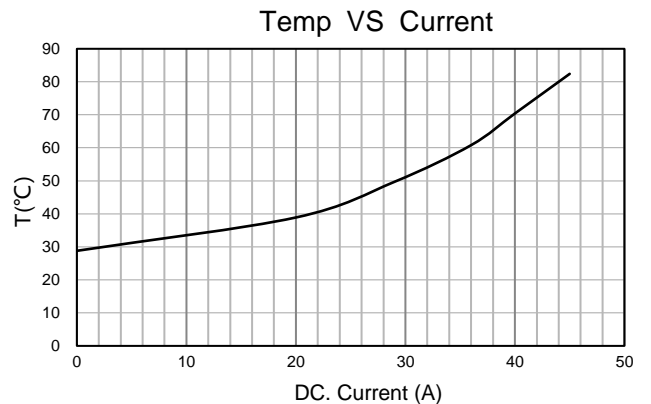
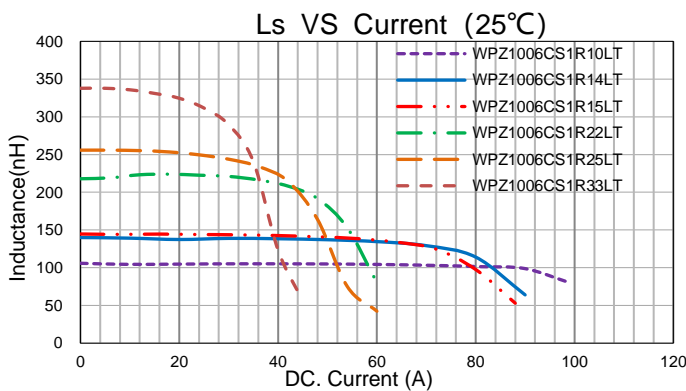

TYPICAL ELECTRICAL CHARACTERISTICS

WPZ10075B1 Series

Ls VS Current (25°C)

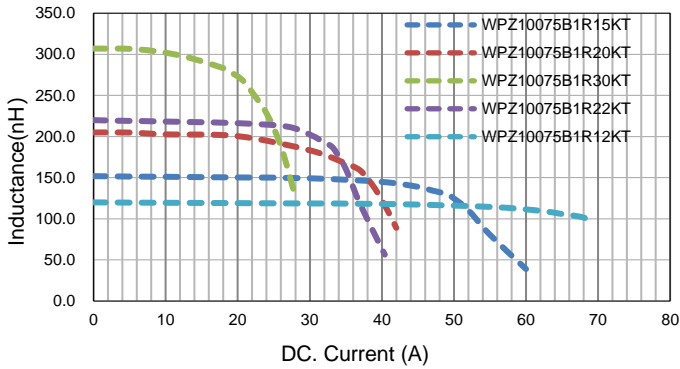

Temp VS Current

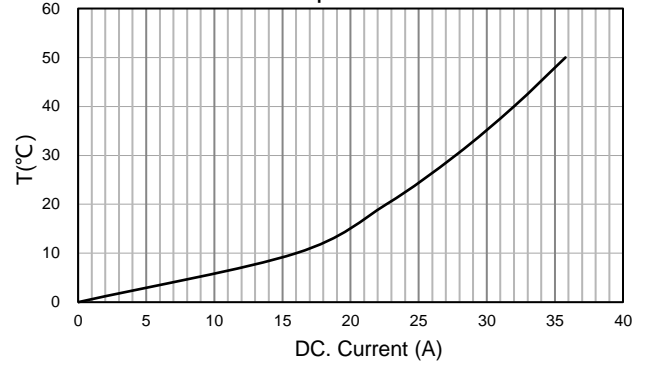

WPZ10075S1 Series

Ls VS Current (25°C)

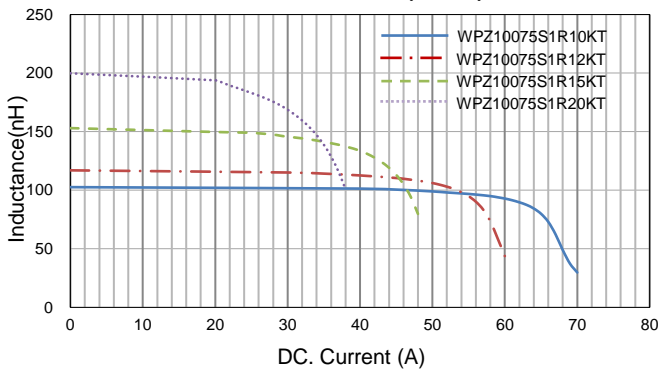

Temp VS Current

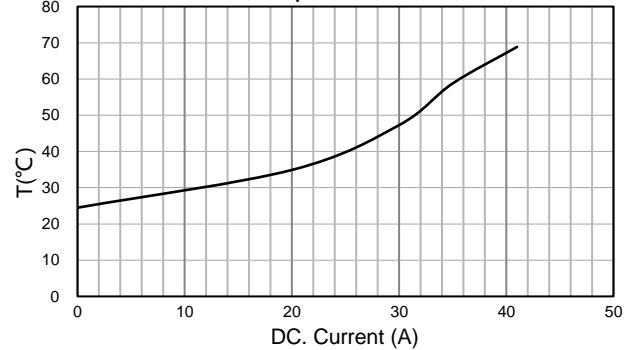

WPZ10075M1 Series

Ls VS Current (25°C)

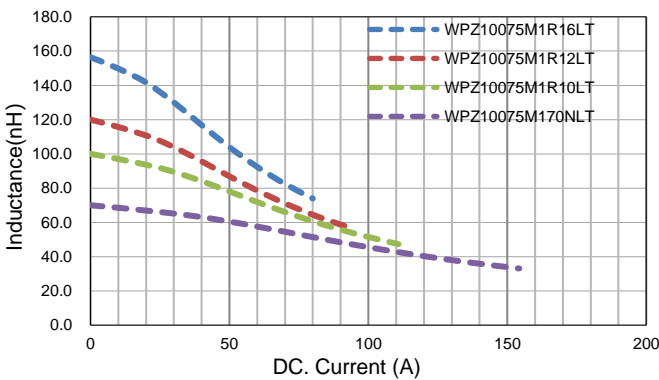

Temp VS Current

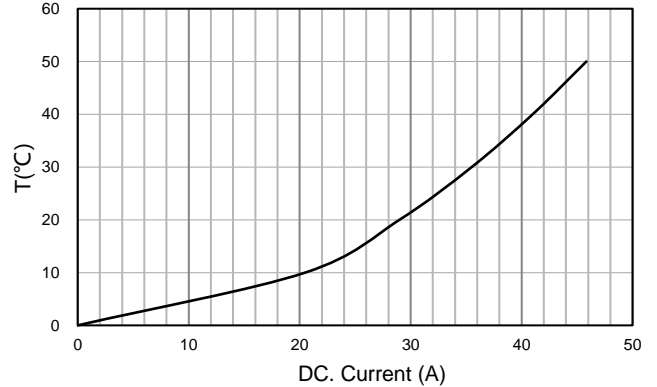

WPZ1007AS1 Series

Ls VS Current (25°C)

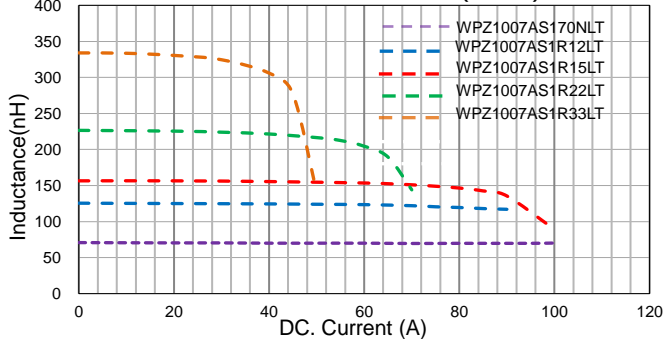

Temp VS Current

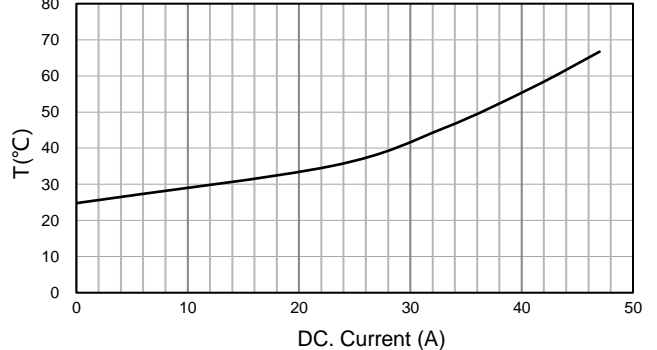

TYPICAL ELECTRICAL CHARACTERISTICS

WPZ1007CS1 Series

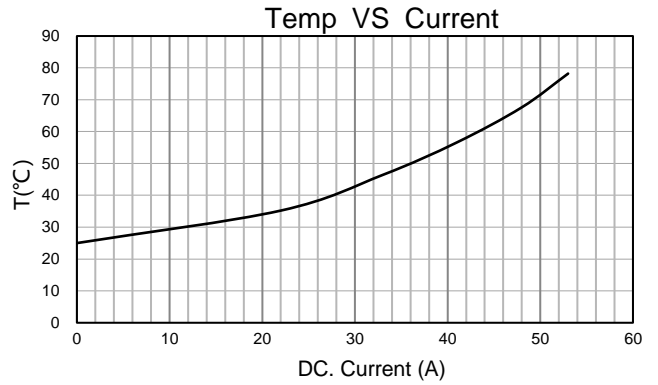
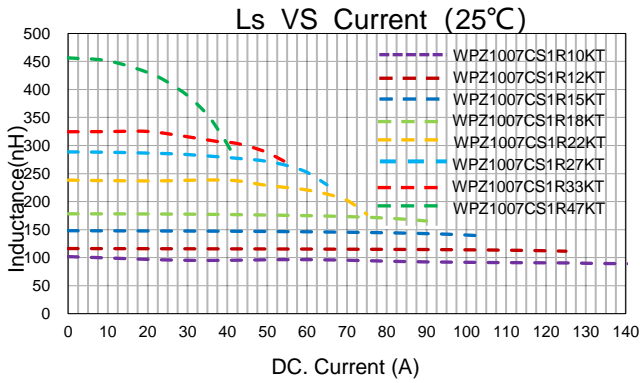

WPZ10087S1 Series

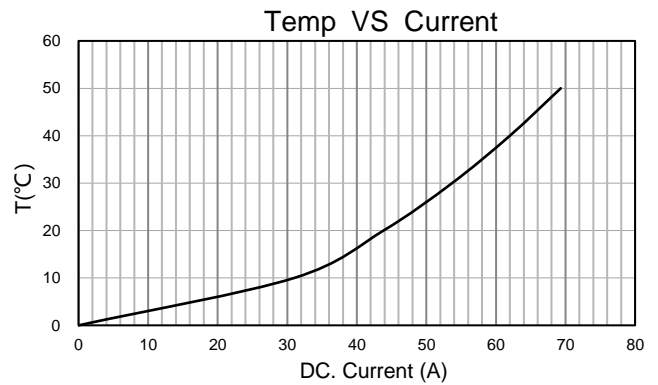
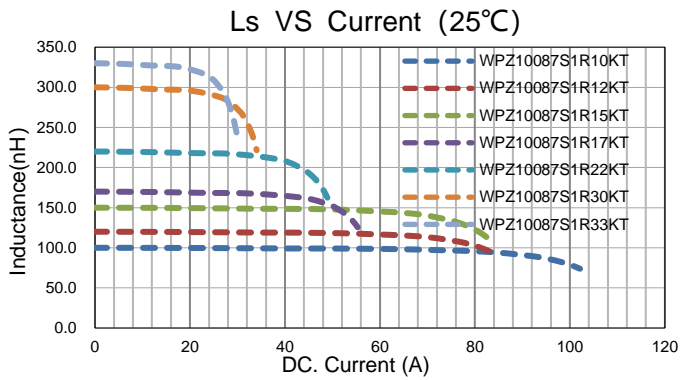

WPZ10087B1 Series

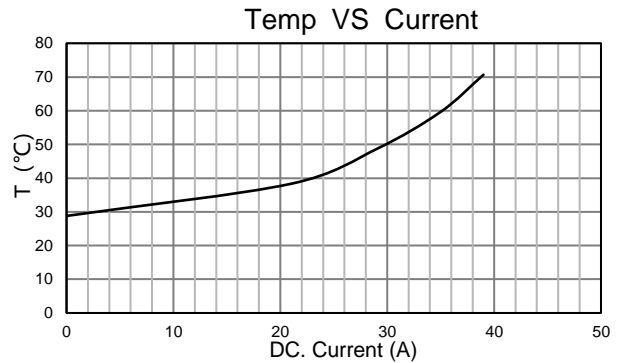
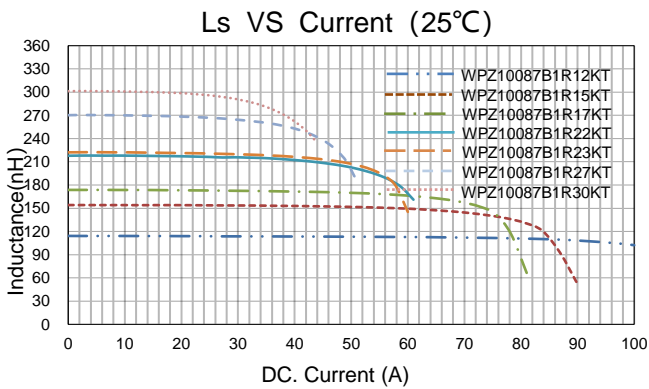

WPZ10088S1 Series

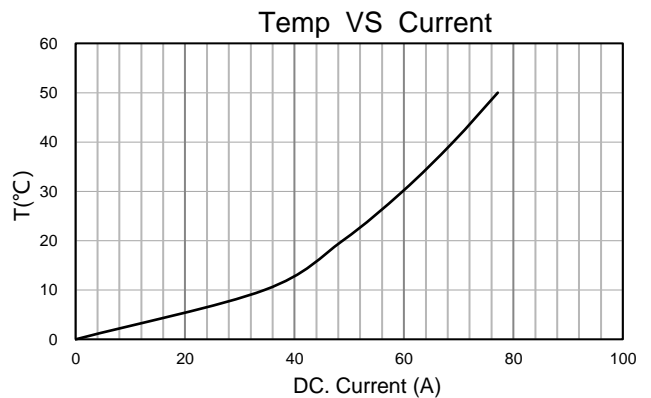
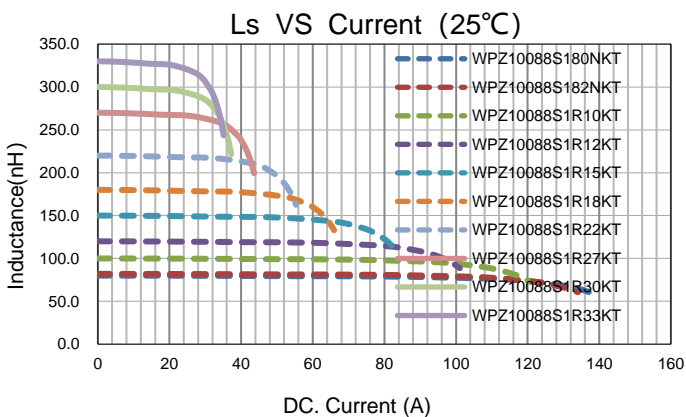

TYPICAL ELECTRICAL CHARACTERISTICS

WPZ11068S1 Series

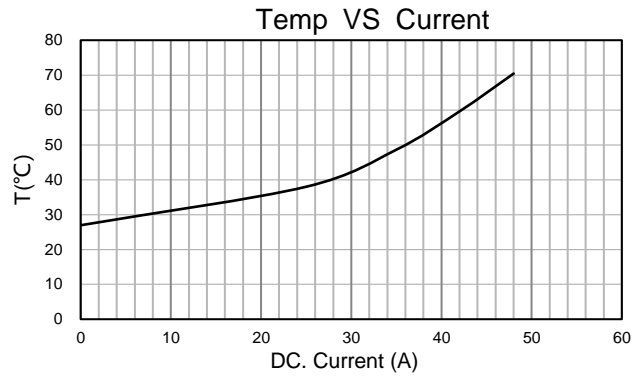
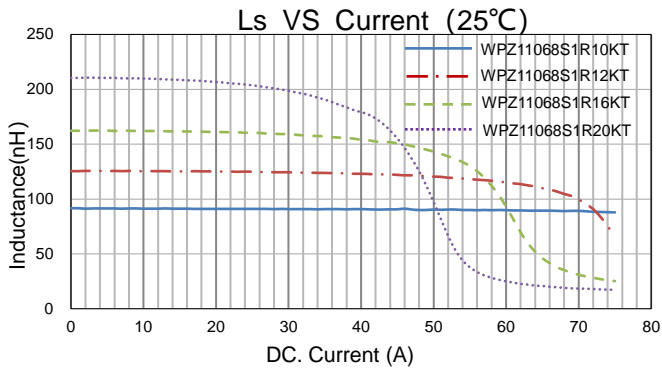

WPZ11077S1 Series

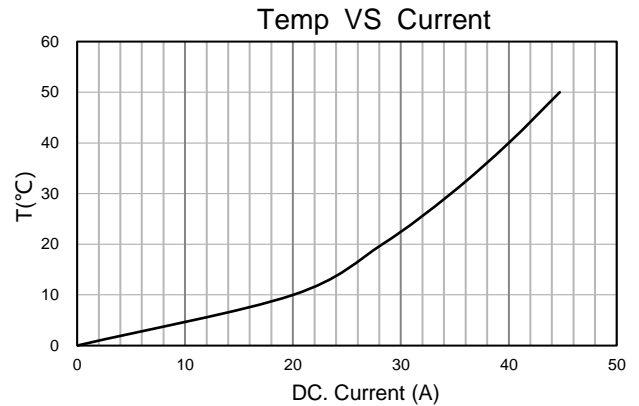
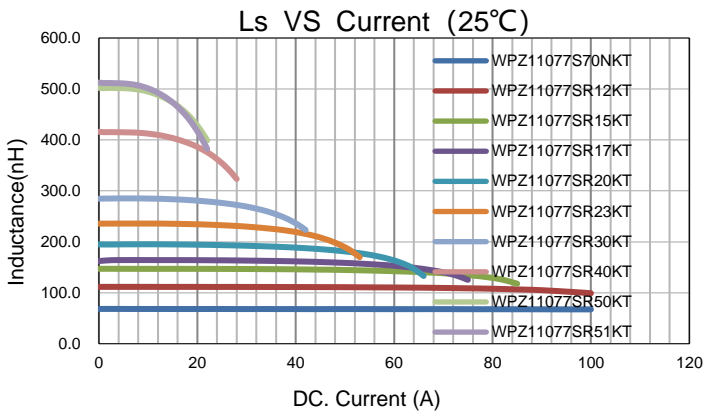

WPZ13083S1 Series

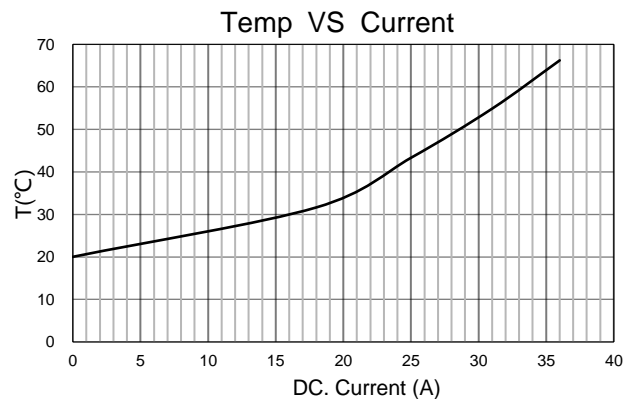
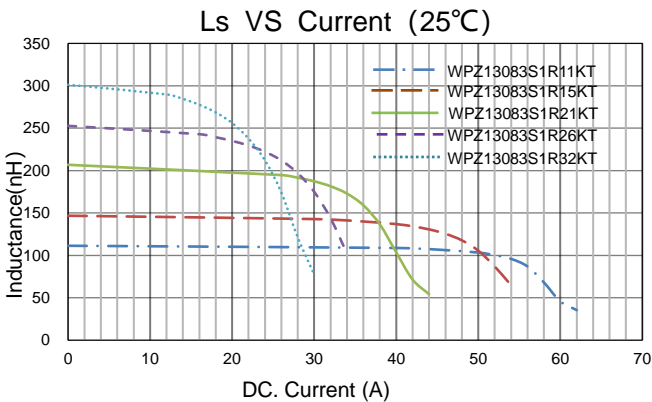

WPZ13138S1 Series

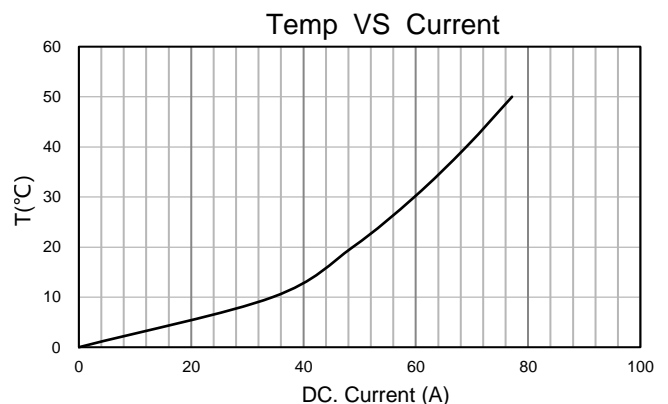
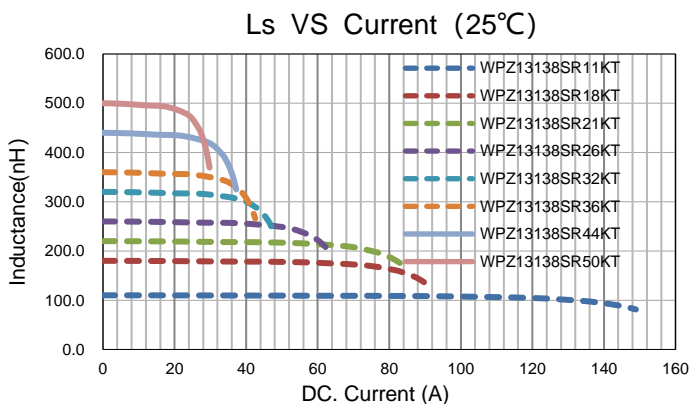

TYPICAL ELECTRICAL CHARACTERISTICS

WPZ06065S1 Series

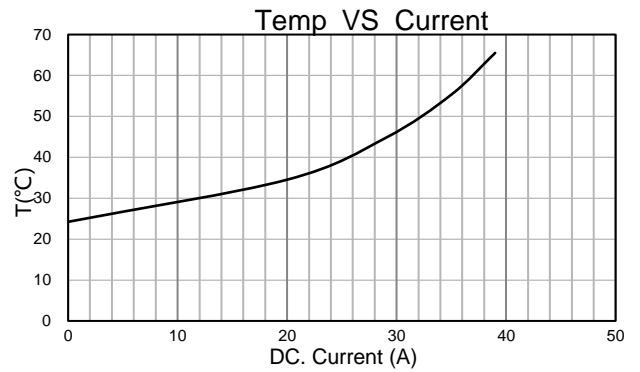
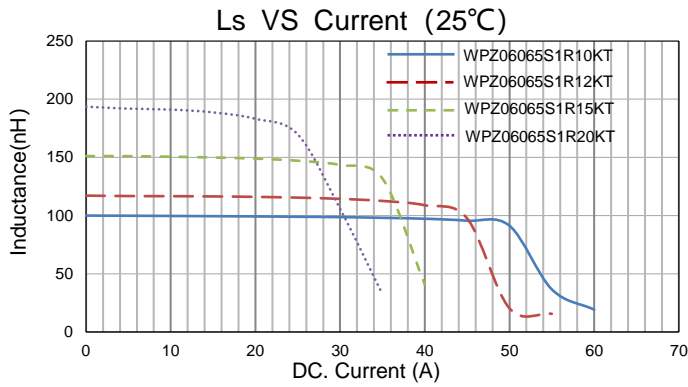

WPZ10103S1 Series

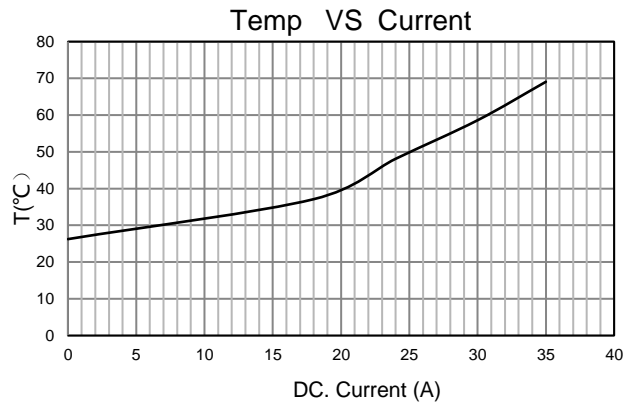
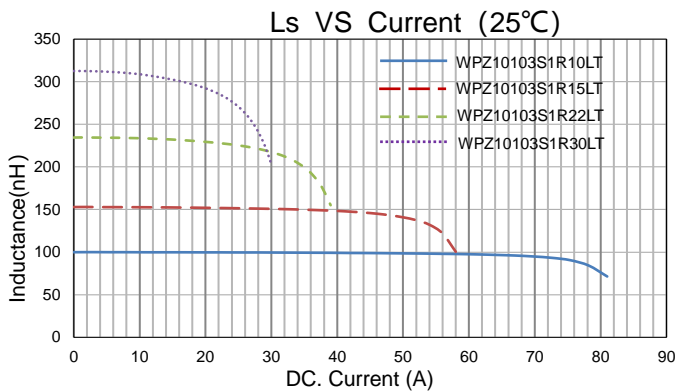

WPZ10106S1 Series

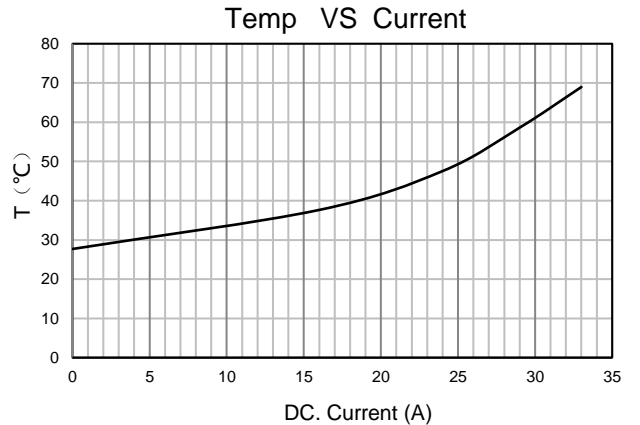
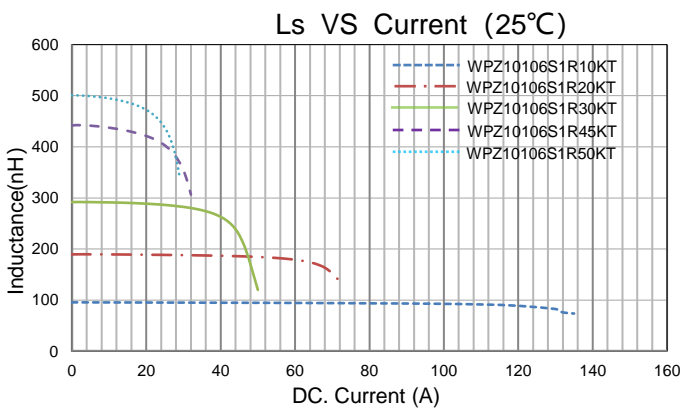

WPZ16123S1 Series

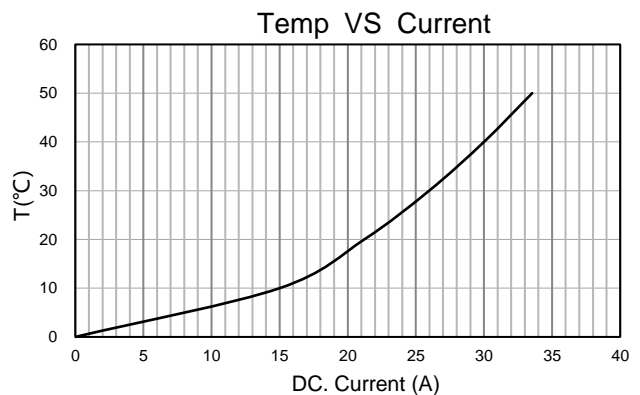
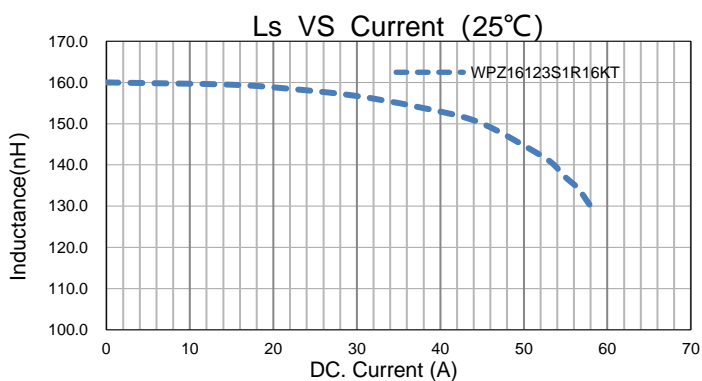

TYPICAL ELECTRICAL CHARACTERISTICS

WPZ18113S1 Series

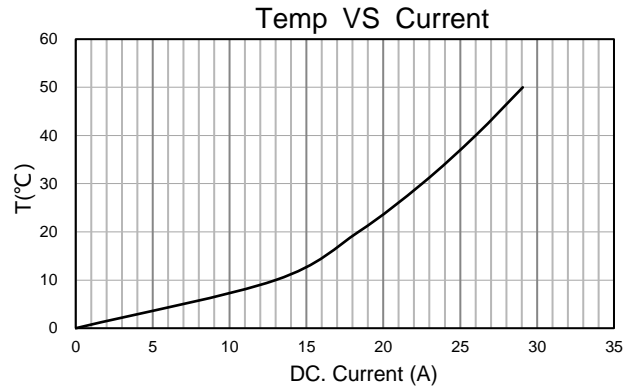
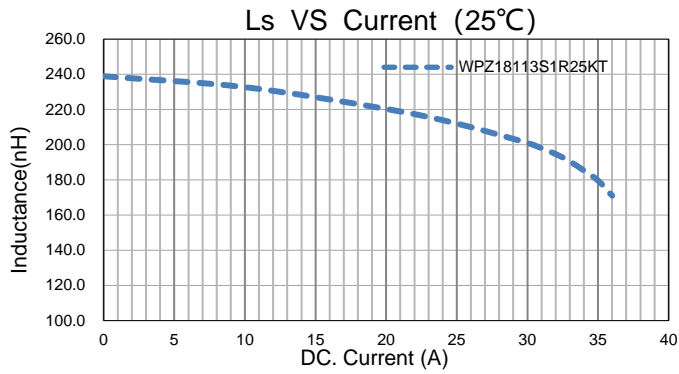

WPZ0906AS2 Series

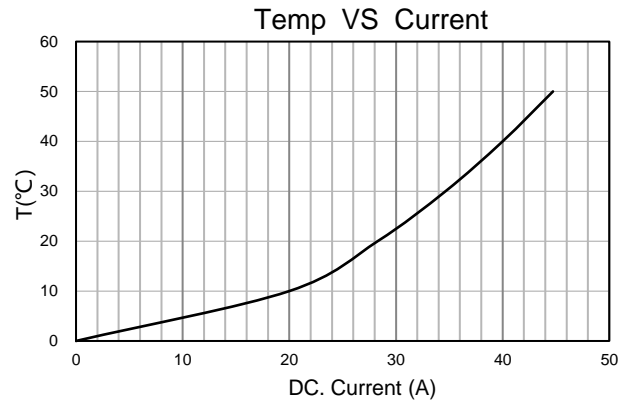
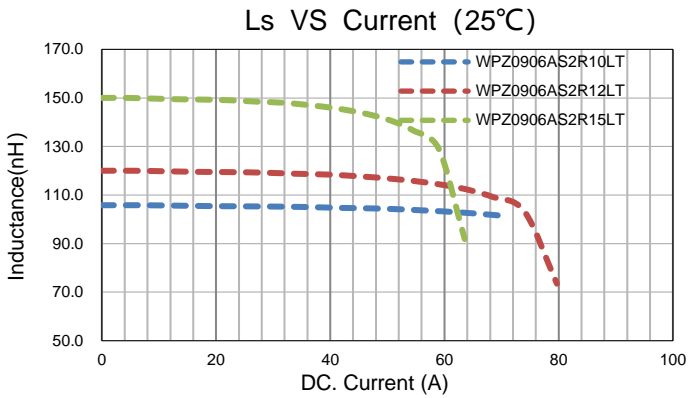

WPZ0906BS2 Series

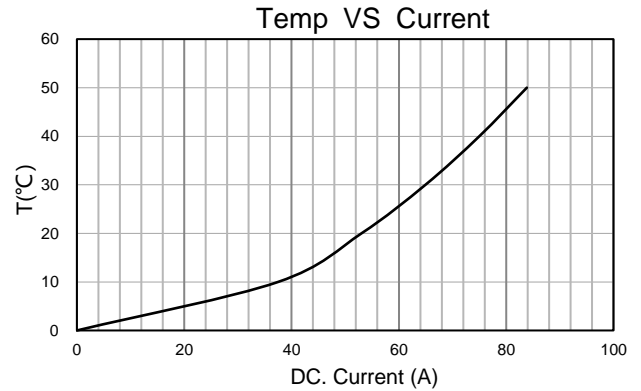
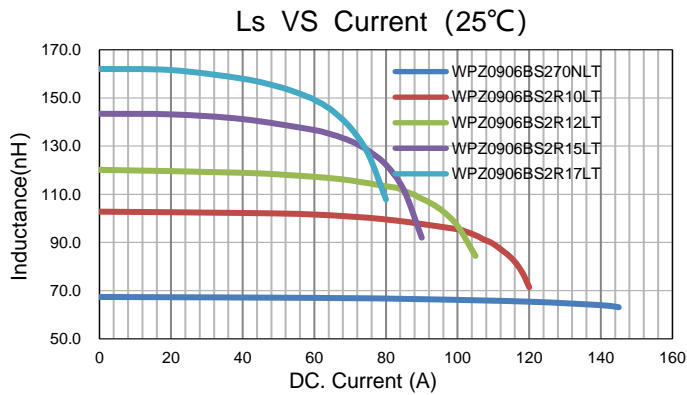

WPZ1206BS2 Series

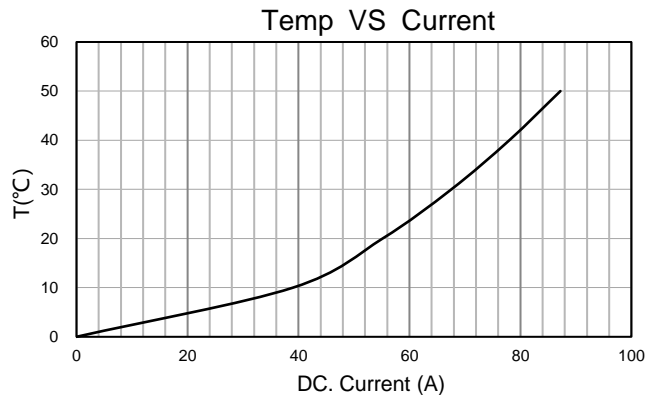
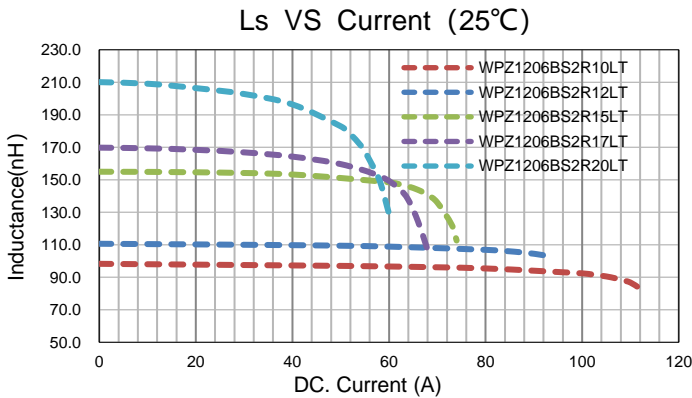

TYPICAL ELECTRICAL CHARACTERISTICS

WPZ1206CF2 Series

Ls VS Current (25°C)

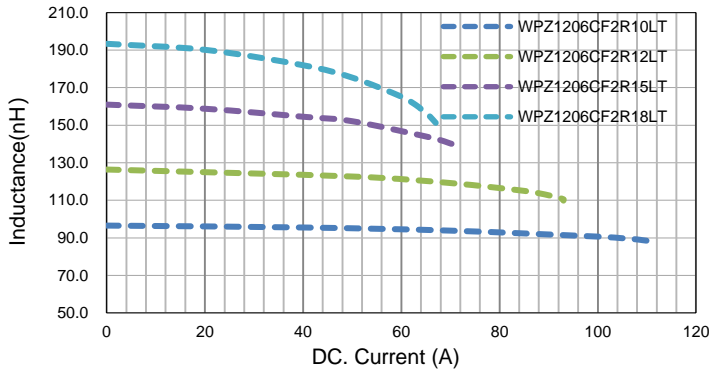

Temp VS Current

