

## WS4695C

**28V, Over-Voltage, Over-Current Protection Load Switch with Adjustable Current-Limit Control**

[Http://www.omnivision-group.com](http://www.omnivision-group.com)

### Descriptions

The WS4695C is a small, low RON, single channel load switch with controlled slew rate. The device can operate over an input voltage range of 2.6 V to 5.5 V and can set current limit from 0.1A to 3.5A.

The controlled rise time of the device greatly reduces inrush current caused by large bulk load capacitance, thereby reducing or eliminating power supply droop. The WS4695C has a True Reverse-Current Blocking (TRCB) function that obstructs unwanted reverse current from VOUT to VIN during ON and OFF states. The small size and low RON makes the device ideal for being used in space constrained, battery powered applications. The wide input voltage range of the switch makes it a versatile solution for many different voltage rails.

The WS4695C are available in CSP-12L package. Standard products are Pb-free and Halogen-free.

### Features

- Input Voltage Range :2.6V~5.5V
- Absolute Rating at V<sub>OUT</sub> :28V
- Maximum Output current :4A
- Adjustable Current Limit :0.1A~3.5A  
2A ~3.5A with 20% Accuracy
- True Reverse-Current Blocking (TRCB)
- Under-Voltage Lockout&Thermal Shutdown
- CSP-12L

### Applications

- Smart Phones, Tablet PCs
- Storage, DSLR, and Portable Devices

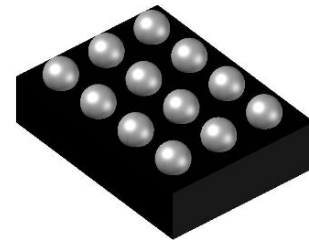

**CSP-12L (Bottom View)**

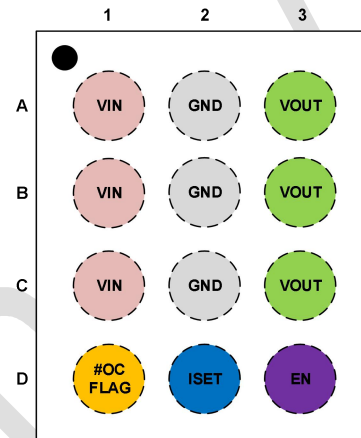

**Pin Configuration (Top View)**

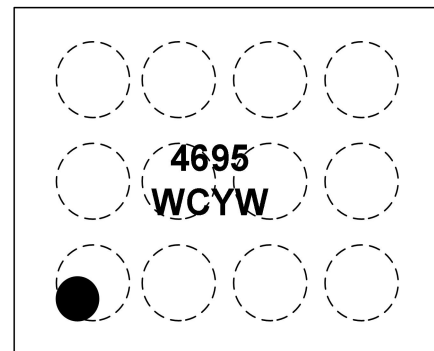

### Marking (Top View)

**4695:Device Code**

**WC:Special Code**

**Y :Year Code**

**W:Week Code**

### Order information

Device	Marking	Package	Shipping
WS4695C-12/TR	4695 WCYW	CSP-12L	3000/Reel&Tape

### Typical Application

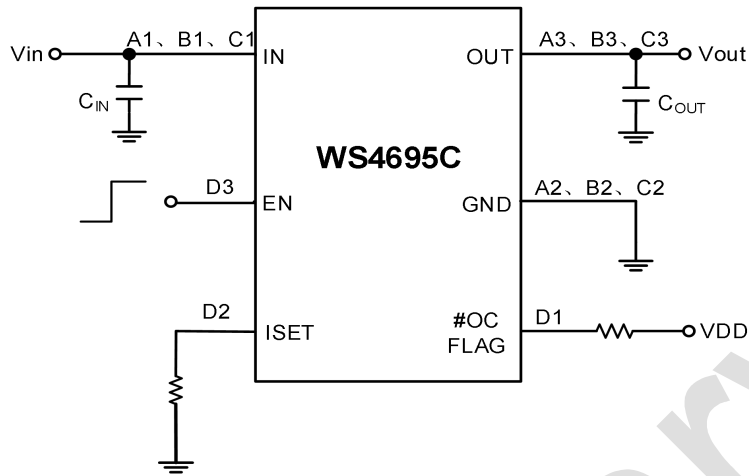

### Pin Description

Pin Number	Symbol	Description
A3、B3、C3	OUT	Output pin
A1、B1、C1	IN	Input pin
A2、B2、C2	GND	Ground
D3	EN	ON/OFF Control Input: Active HIGH
D2	ISET	Current Limit Set Input: A resistor from ISET to ground sets the current limit for the switch.
D1	#OCFLAG	Fault Output: Active LOW, open-drain output that indicates an input over current. External pull-up resistor to VDD is required.

### Block Diagram

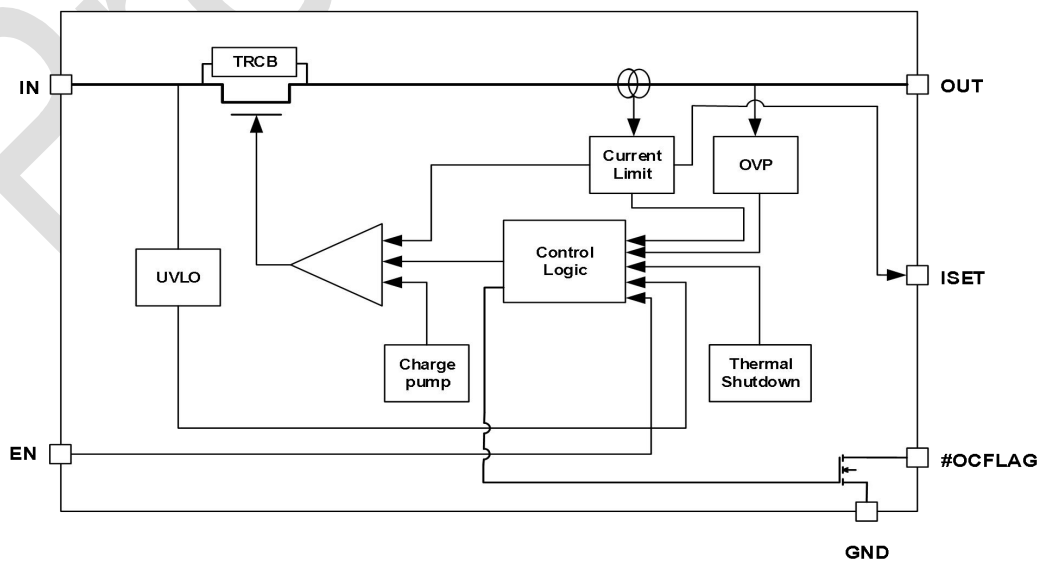

## Absolute Maximum Ratings

These are stress ratings only. Stresses exceeding the range specified under “Absolute Maximum Ratings” may cause substantial damage to the device. Functional operation of this device at other conditions beyond those listed in the specification is not implied and prolonged exposure to extreme conditions may affect device reliability.

Parameter		Symbol	Min.	Max.	Unit
V <sub>OUT</sub> to GND, V <sub>OUT</sub> to V <sub>IN</sub>		OUT	-0.3	28.0	V
Other Pins to GND		EN, IN, ISET, #OCFLAG	-0.3	6.0	V
Maximum Continuous Switch Current <sup>(1)</sup>		I <sub>SW</sub>	4.0		A
Operating Junction Temperature		T <sub>J</sub>	-40	150	°C
Storage Temperature Range		T <sub>STG</sub>	-65	150	°C
Lead Temperature		T <sub>L</sub>	260		°C
ESD	Human Body Model, JESD22-A114	HBM	±2000		V
	Charged Device Model, JESD22-C101	CDM	±1000		V
	Air Discharge(V <sub>IN</sub> , V <sub>OUT</sub> to GND)	Air Discharge	±15000		V
	Contact Discharge(V <sub>IN</sub> , V <sub>OUT</sub> to GND)	Contact Discharge	±8000		V

**Notes:**

(1) maximum Junction Temperature = 85°C

## Recommend Operating Ratings

The Recommended Operating Conditions table defines the conditions for actual device operation. Recommended operating conditions are specified to ensure optimal performance to the datasheet specifications.

Parameter	Symbol	Min.	Max.	Unit
Supply Voltage	V <sub>IN</sub>	2.6	5.5	V
Other Pins	EN, IN, ISET, #OCFLAG	2.5	5.5	V
Operating ambient temperature	T <sub>A</sub>	-40	85	°C
Thermal Resistance, R <sub>θJA</sub> (CSP-12L) <sup>(2)</sup>	R <sub>θJA</sub>	88		°C/W

**Notes:**

(2) :Surface mounted on FR-4 Board using 2 oz, 1 square inch Cu area, PCB board size 1.5\*1.5 square inches.

**ELECTRICAL CHARACTERISTICS**
**(VIN=5V, CIN=1μF, COUT=1μF, at Ta=25°C, unless otherwise noted)**

Parameter	Symbol	Condition	Min.	Typ.	Max.	Unit
<b>Basic Operation</b>						
Input Voltage	V <sub>IN</sub>		2.6		5.5	V
Quiescent Current	I <sub>Q</sub>	V <sub>IN</sub> =V <sub>EN</sub> , V <sub>OUT</sub> =Open		80	205	μA
Shutdown Current	I <sub>SD</sub>	V <sub>IN</sub> =5.5V, V <sub>OUT</sub> =0V, V <sub>EN</sub> =GND		0.1	4	μA
Off Supply Current	I <sub>Q(OFF)</sub>	V <sub>EN</sub> =GND, V <sub>OUT</sub> =Open		1	2	μA
On Resistance	R <sub>ON</sub>	V <sub>IN</sub> =V <sub>EN</sub> =5.0V, I <sub>OUT</sub> =1A		40	67	mΩ
		V <sub>IN</sub> =V <sub>EN</sub> =3.7V, I <sub>OUT</sub> =1A		44	72	
EN Logic High Voltage	V <sub>IH</sub>	V <sub>IN</sub> =2.5V to 5.5V, I <sub>OUT</sub> =0.1A	1.1			V
EN Logic Low Voltage	V <sub>IL</sub>	V <sub>IN</sub> =2.5V to 5.5V, I <sub>OUT</sub> =0.1A			0.4	V
#OCFLAG Output Logic Low Voltage	V <sub>IL_FLAG</sub>	V <sub>IN</sub> =5V, I <sub>SINK</sub> =10mA		0.1	0.2	V
		V <sub>IN</sub> =2.5V, I <sub>SINK</sub> =10mA		0.15	0.3	V
#OCFLAG Output Logic High Leakage Current	I <sub>FLAG_LK</sub>	V <sub>IN</sub> =5V, Switch on		0.1	1	μA
EN Input Leakage	I <sub>ON</sub>	V <sub>EN</sub> =0V to 5V			1	μA
Pull-Down Resistance at EN Pin	R <sub>EN_PD</sub>	V <sub>IN</sub> =2.5~5.5V, V <sub>EN</sub> =V <sub>IN</sub> TA= -40 to 85 °C		14		MΩ
<b>Over-Voltage Protection</b>						
Output OVP Lockout	V <sub>OV_TRIP</sub>	V <sub>OUT</sub> Rising Threshold	5.5	5.8	6	V
		V <sub>OUT</sub> Falling Threshold		5.5		
Output OVP Hysteresis	OUT <sub>HYS</sub>			0.3		V
OVP Response Time	t <sub>OV</sub>	I <sub>OUT</sub> =0.5A, C <sub>L</sub> =1μF, TA=25°C, V <sub>OUT</sub> from 5.5V to 6.0V	1		4	μs
<b>Over-Current Protection</b>						
Current Limit	I <sub>LIM</sub>	V <sub>IN</sub> =V <sub>EN</sub> =5V, R <sub>SET</sub> =300Ω	2975	3500	4000	mA
		V <sub>IN</sub> =V <sub>EN</sub> =5V, R <sub>SET</sub> =500Ω	1768	2080	2390	
Under-Voltage Lockout	V <sub>UVLO</sub>	V <sub>IN</sub> Increasing		2.4		V
		V <sub>IN</sub> Decreasing		2.2		
UVLO Hysteresis	V <sub>UVLO_HYS</sub>			200		mV
RCB Protection Trip Point	V <sub>T_RCB</sub>	V <sub>OUT</sub> - V <sub>IN</sub>		50		mV
RCB Protection Release Trip Point	V <sub>R_RCB</sub>	V <sub>IN</sub> - V <sub>OUT</sub>		50		mV
RCB Hysteresis	V <sub>RCB_HYS</sub>			100		mV

**ELECTRICAL CHARACTERISTICS (continued)**
**(VIN=5V, CIN=1μF, COUT=1μF, at Ta=25°C, unless otherwise noted)**

Parameter	Symbol	Condition	Min.	Typ.	Max.	Unit
Default RCB Response Time <sup>(3)</sup>	t <sub>RCB</sub>	V <sub>IN</sub> =5V, V <sub>EN</sub> =High/Low		2		μs
RCB Current	I <sub>RCB</sub>	V <sub>EN</sub> =0V, V <sub>OUT</sub> =5.5V		7		μA
Over-Current Response Time <sup>(3)</sup>	t <sub>OCP</sub>	Moderate Over-Current Condition, I <sub>OUT</sub> ≥ I <sub>LIM</sub> , V <sub>OUT</sub> ≤ V <sub>IN</sub>		10		μs
Over-Current Flag Response Time	t <sub>OC_FLAG</sub>	When Over-Current Occurs to Flag Pulling LOW		9		ms
Thermal Shutdown	TSD	Shutdown Threshold		150		°C
		Return from Shutdown		130		
		Hysteresis		20		
Turn-On Delay	T <sub>DON</sub>	V <sub>IN</sub> =5V, R <sub>L</sub> =100Ω, C <sub>L</sub> =1uF R <sub>SET</sub> =2kΩ, T <sub>A</sub> =25°C		1.1		ms
V <sub>OUT</sub> Rise Time	T <sub>R</sub>			0.6		
Turn-On Time	T <sub>ON</sub>			1.7		
Turn-Off Delay	T <sub>DOFF</sub>			10		μs
V <sub>OUT</sub> Fall Time	T <sub>F</sub>			240		
Turn-Off Time	T <sub>OFF</sub>			250		

**Notes:**
<sup>(3)</sup> This parameter is guaranteed by design.

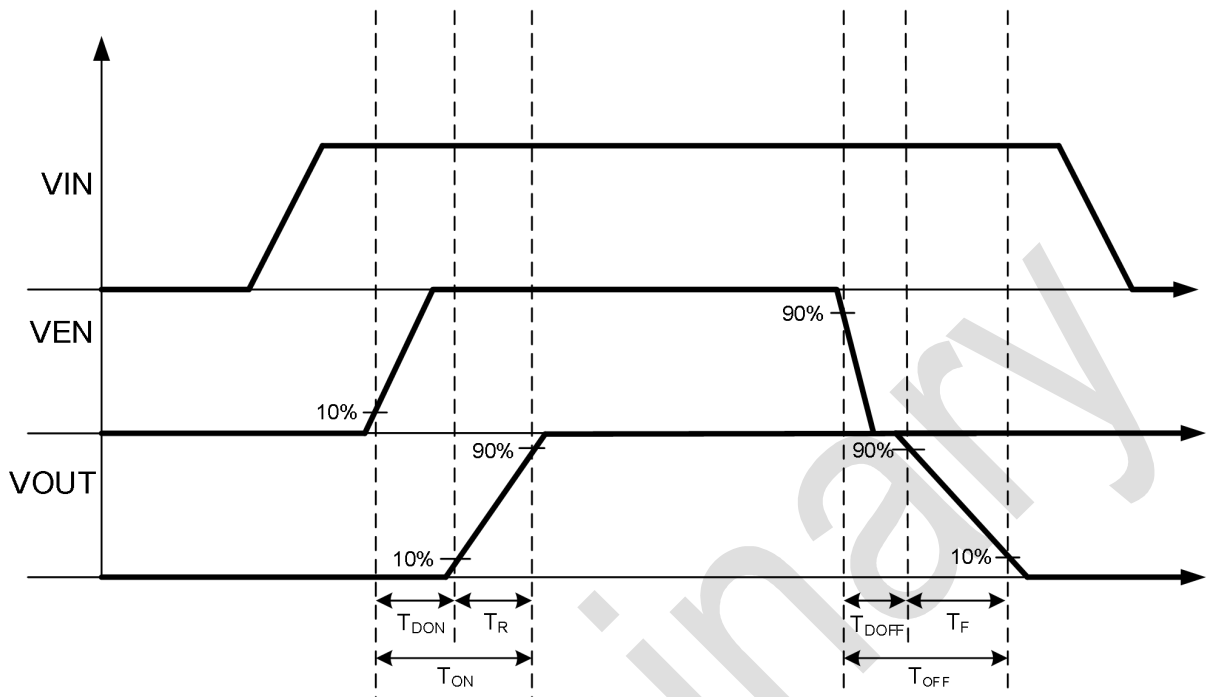
**Timing Diagram**

Note:  $T_{ON} = T_{DON} + T_R$ ,  $T_{OFF} = T_{DOFF} + T_F$ .

**Figure 1. Timing Diagram**

**Typical characteristics**

( $T_a=25^\circ\text{C}$ ,  $V_{IN}=V_{EN}=5\text{V}$ ,  $C_{IN}=1\mu\text{F}$ ,  $C_{OUT}=1\mu\text{F}$ , unless otherwise noted)

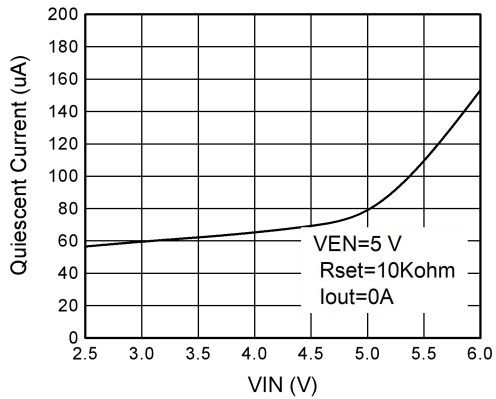
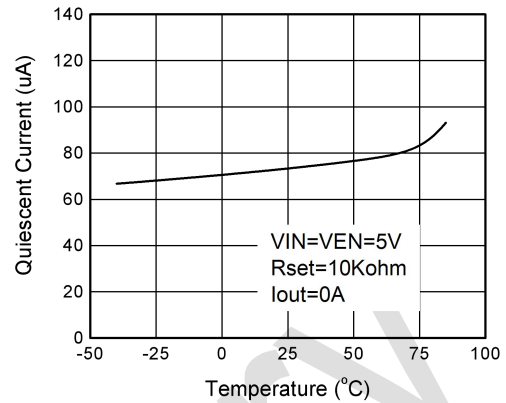
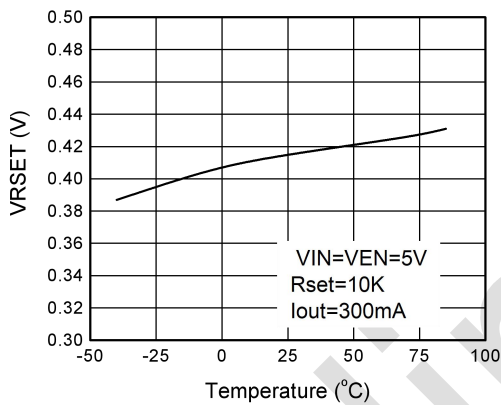
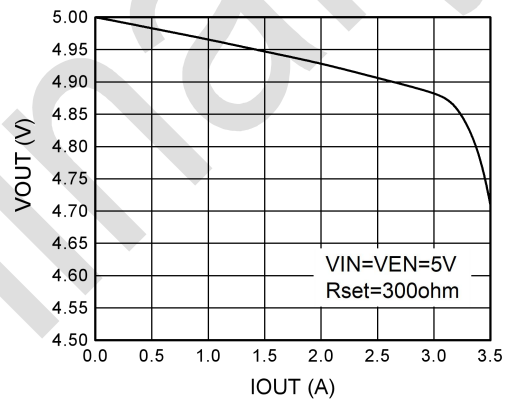
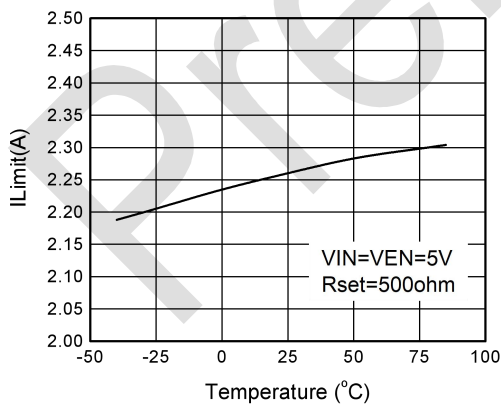
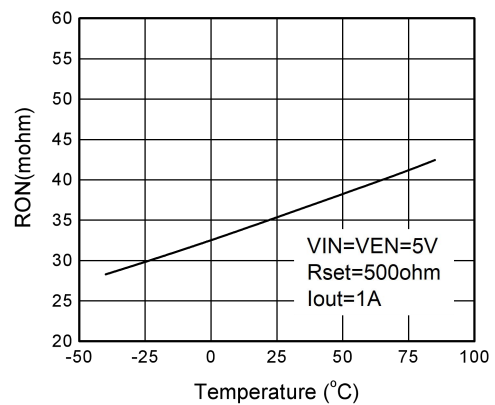
 **$I_Q$  vs.  $V_{IN}$** 

 **$I_Q$  vs. Temp.**

 **$V_{RSET}$  vs. Temp.**

 **$V_{OUT}$  vs.  $I_{OUT}$** 

 **$I_{LIMIT}$  vs. Temp.**

 **$R_{ON}$  vs. Temp.**

$C_{IN}=C_{OUT}=1\mu F, V_{IN}=V_{EN}=5V, R_{SET}=500\Omega, I_{OUT}=0mA$

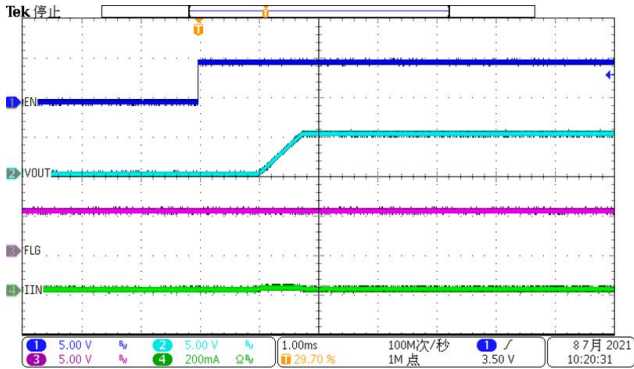

Figure 1. Start up by EN

$C_{IN}=C_{OUT}=1\mu F, V_{IN}=V_{EN}=5V, R_{SET}=500\Omega, I_{OUT}=0mA$

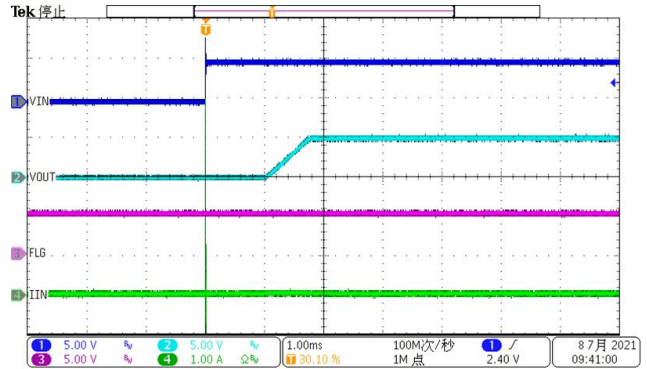

Figure 2. Start up by VIN

$C_{IN}=C_{OUT}=1\mu F, V_{IN}=V_{EN}=5V, R_{SET}=500\Omega, I_{OUT}=0mA$

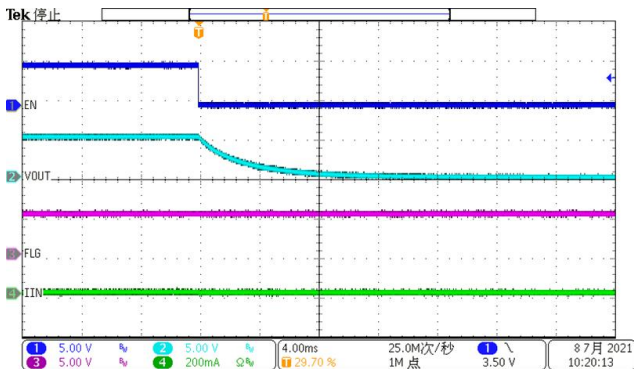

Figure 3. Shut down by EN

$C_{IN}=C_{OUT}=1\mu F, V_{IN}=V_{EN}=5V, R_{SET}=500\Omega, I_{OUT}=0mA$

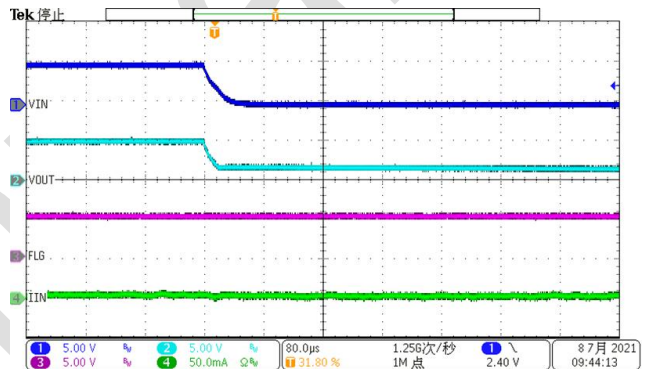

Figure 4. Shut down by EN

$C_{IN}=10\mu F, C_{OUT}=1\mu F, V_{IN}=V_{EN}=5V, R_{SET}=500\Omega, V_{OUT}=GND$

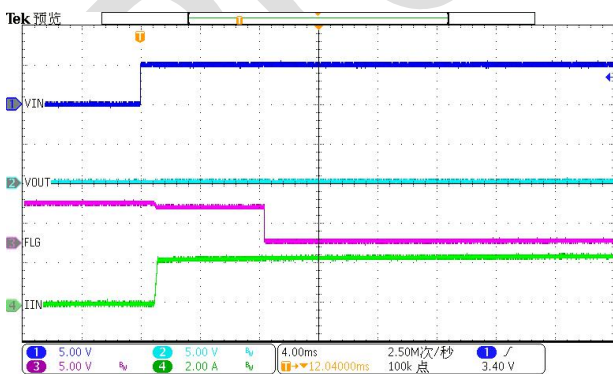

Figure 5. Short before Power on

$C_{IN}=10\mu F, C_{OUT}=1\mu F, V_{IN}=V_{EN}=5V, R_{SET}=500\Omega, V_{OUT}=GND$

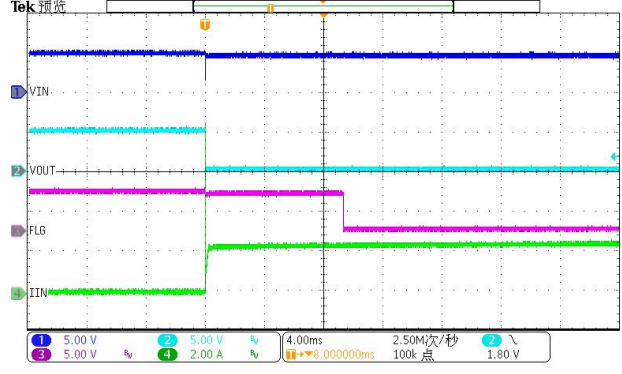

Figure 6. Short after Power on



## Detailed Description

### Input Capacitor

To limit the voltage drop on the input supply caused by transient in-rush currents when the switch turns on into a discharged load capacitor or short-circuit, a capacitor needs to be placed between VIN and GND. A 1- $\mu$ F ceramic capacitor, CIN, placed close to the pins, is usually sufficient. Higher values of CIN can be used to further reduce the voltage drop during high-current application.

### Output capacitor

An output capacitor should be placed between the VOUT and GND pins. This capacitor prevents parasitic board inductance from forcing VOUT below GND when the switch is on. This capacitor also prevents reverse inrush current from creating a voltage spike that could damage the device in the case of a VOUT short.

### Fault Reporting

Upon the detection of an over-current, #OC\_FLAG signal the fault by activating LOW.

### Current Limiting

The current limit ensures that the current through the switch does not exceed the maximum set value, while not limiting the minimum value. The current at which the part's limit is adjustable through the selection of the external resistor connected to the ISET pin. Information for selecting the resistor is found in the section below. The device acts as a constant-current source when the load draws more than the maximum value set by the device until thermal shutdown occurs. The device recovers if the die temperature drops below the threshold temperature.

### Under-Voltage Lockout (UVLO)

The under-voltage lockout turns the switch off if the input voltage drops below the lockout threshold. With the EN pin active, the input voltage rising above the UVLO threshold releases the lockout and enables the switch.

### True Reverse-Current Blocking

The true reverse-current blocking feature protects the input source against current flow from output to input regardless of whether the load switch is on or off.

### Thermal Shutdown

The thermal shutdown protects the die from internally or externally generated excessive temperature. During an over-temperature condition, the switch is turned off. The switch automatically turns on again if the temperature of the die drops below the threshold temperature.

### Setting Current Limit

The current limit is set with an external resistor connected between the ISET and GND pins.

It can be calculated as:

$$I_{LIMIT}(A) = \frac{1000}{R_{set}(\Omega)}$$

The resistor tolerance of 1% or less is recommended.

### Layout guide

For best performance, all traces should be as short as possible. To be most effective, the input and output capacitors should be placed close to the device to minimize the effect that parasitic trace inductance may have on normal and short-circuit operation. Using wide traces for VIN, VOUT, GND helps minimize parasitic electrical effects along with minimizing the case-to ambient thermal impedance.

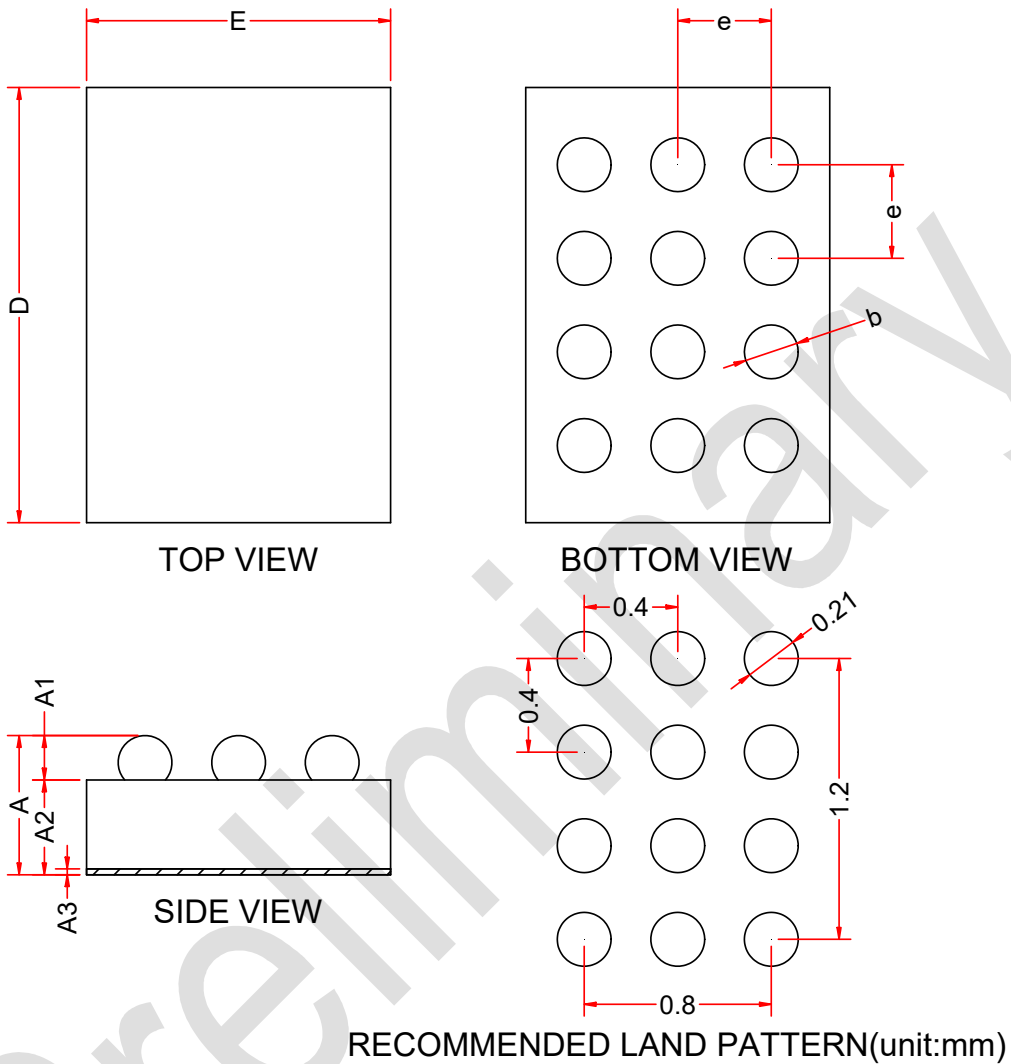
**PACKAGE OUTLINE DIMENSIONS**
**CSP-12L**

Symbol	Dimensions in Millimeters		
	Min.	Typ.	Max.
A	0.45	0.50	0.54
A1	0.18	0.20	0.22
A2	0.27	0.30	0.32
A3	0.025REF		
D	1.80	1.83	1.86
E	1.30	1.33	1.36
b	0.24	0.26	0.28
e	0.40BSC		

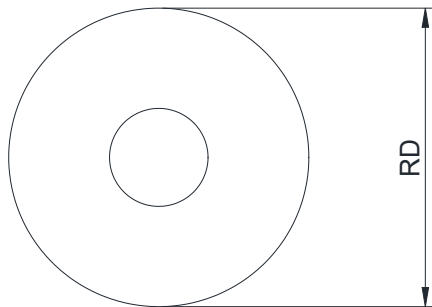
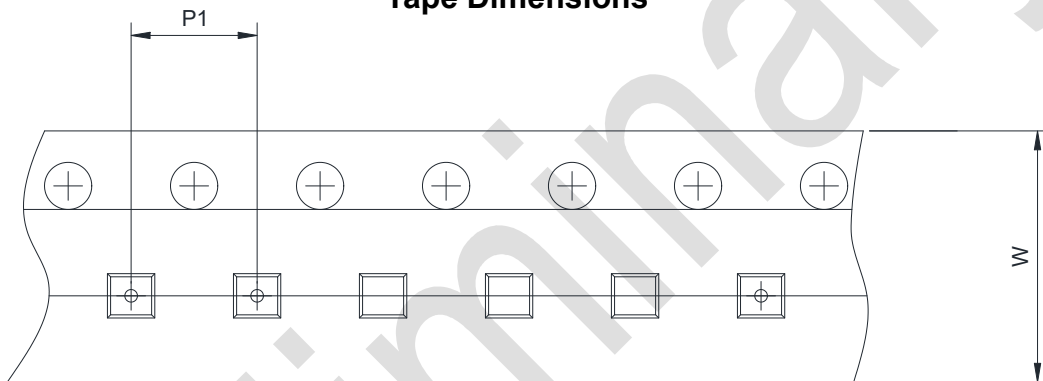
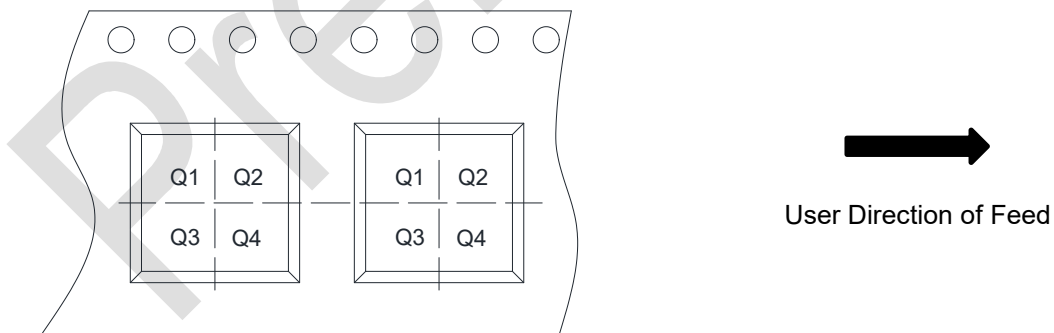
**TAPE AND REEL INFORMATION**
**Reel Dimensions**

**Tape Dimensions**

**Quadrant Assignments For PIN1 Orientation In Tape**

RD	Reel Dimension	<input checked="" type="checkbox"/> 7inch	<input type="checkbox"/> 13inch
W	Overall width of the carrier tape	<input checked="" type="checkbox"/> 8mm	<input type="checkbox"/> 12mm <input type="checkbox"/> 16mm
P1	Pitch between successive cavity centers	<input type="checkbox"/> 2mm	<input checked="" type="checkbox"/> 4mm <input type="checkbox"/> 8mm
Pin1	Pin1 Quadrant	<input checked="" type="checkbox"/> Q1	<input type="checkbox"/> Q2 <input type="checkbox"/> Q3 <input type="checkbox"/> Q4